

**ADDENDUM NUMBER ONE
TO
BIDDING AND CONTRACT DOCUMENTS
FOR
RUNWAY 5R-23L REHABILITATION PROJECT - CONSTRUCTION PHASE 1
PIEDMONT TRIAD INTERNATIONAL AIRPORT
GREENSBORO, NORTH CAROLINA**

TO: All Prospective Bidders

Date: Tuesday, November 21, 2017

This addendum forms a part of the Contract Documents and modifies the original Bidding Documents as noted below. Acknowledge receipt of this addendum in the space provided on the Bid Form (B-4) AND by acknowledging receipt of this Addendum by returning the attached Acknowledgement Form (Attachment A) via fax, email or mail. FAILURE TO DO SO MAY SUBJECT A BIDDER TO DISQUALIFICATION.

PREBID MEETING

The minutes to the Prebid Meeting held on November 9, 2017 are attached.

DRAWINGS

- Delete sheet C-451 Drainage Details in its entirety and replace with the attached C-451.
- The grade tables are provided in Microsoft Excel format.

END OF ADDENDUM NUMBER ONE

**ATTACHMENT A
ACKNOWLEDGEMENT FORM**

Contract Supervisor,

I, (we) am/are returning this acknowledgement to your office as a receipt to the following Addendum:

PIEDMONT TRIAD INTERNATIONAL AIRPORT

RUNWAY 5R-23L REHABILITATION PROJECT, CONSTRUCTION PHASE 1

ADDENDUM NO. 1

Company Name

BY: _____
Recipient's Signature

Date: _____

This acknowledgement must be returned to:

Heather Leopardi
Michael Baker Engineering, Inc.
200 Centreport Drive, Suite 350
Greensboro, NC 27409
Phone: (412) 269-6407
Fax: (412) 375-3990
hleopardi@mbakerintl.com

PROJECT: Piedmont Triad International Airport
Runway 5R-23L Rehabilitation Project, Construction Phase 1

DATE: Thursday, November 9, 2017 at 10:00 am

PLACE: Stanley Frank Board Room

INTRODUCTIONS:

Deputy Executive Director – Alex Rosser – 336.665.5620/rossera@gsoair.org

Project Manager – Lisa Elmore – 336.665.5639/elmorel@gsoair.org

Project Manager – Lorin Akins – 336-665-5604/akinsl@gsoair.org

Assistant Project Manager– Michael Baker–Heather Leopardi,
412.269.6407/hleopardi@mbakerintl.com

PROJECT SUMMARY

- a. Mill and overlay runway, shoulders, and blast pad
- b. TDZ replacement including conduit, cable, cans, and LED fixtures
- c. Replace runway centerline light system, including conduit, cable, cans, existing fixtures to be reinstalled
- d. Replace runway edge/end light system, including conduit, cable, cans, and fixtures
- e. Relocate airfield signs on new base along Taxiway A
- f. Install SMGCS infrastructure
- g. Install underdrain in existing runway shoulders – separate trench from edge lighting
- h. Grade along the runway edges
- i. Groove new runway pavement
- j. Paint entire runway length of runway
- k. Replace drainage structures along Taxiway M
- l. Adjust RW 23L ALSF-2 Light Lane Stations, including replacement of threshold bar
- m. Adjust RW 23L PAPI

PROJECT BIDDING

- a. Base Bid:
 - All work as described above between Runway Stations 159+00 and 200+00
 - 4,100 feet of runway
- b. Add Alternate 1:
 - All work as described above between Runway Stations 157+00 and 159+00
 - 200 feet of runway
- c. Add Alternate 2:
 - All work as described above between Runway Stations 155+00 and 157+00
 - 200 feet of runway
- d. Add Alternate 3:
 - All work as described above between Runway Stations 153+00 and 155+00
 - 200 feet of runway

SCHEDULE:

- a. Last Day for Questions November 27, 2017 - 12:00 p.m. to
hleopardi@mbakerintl.com
- b. Addendum November 30, 2017

- | | |
|-----------------------|-------------------------------------|
| c. Bids Due | December 7, 2017 - 2:00 p.m. |
| d. Bid Opening | December 7, 2017 - 2:00 p.m. |
| e. Notice to Proceed | Administrative NTP – Winter 2018 |
| | Construction NTP – Spring 2018 |
| f. Contract Time | 195 calendar days |

PROJECT DOCUMENTS:

- | | |
|--|---|
| a. Bid Requirements | Instructions to Bidders |
| b. DBE Requirements | 11.9% |
| c. Liquidated Damages | Phase I: \$3,000 per calendar day |
| | Phase II: \$5,000 per calendar day |
| | Total Project: \$3,000 per calendar day |
| d. Bid Security | 5% of total Bid |
| e. Prime contractor to complete at least 25% of the total work as defined in Paragraph 3.2 of the Instructions to Bidders and General Provision 80-01. | |

FUNDING:

- a. FAA Grant Funding

CONSTRUCTION:

- a. Contractors Staging Area
- b. Haul Routes
- c. Airfield Access
- d. Air and Vehicle Traffic Control
- e. Scheduling/Coordination
- f. Detailed Paving Plan
 - Paving Workshop (Owner/Engineer/CM/Contractor)
 - QA/QC Procedures
 - Detailed Plan
 - Production Rates/Lift Thicknesses
 - Rolling and Compaction Procedures
 - Hot and Cold Joints
 - Lighting Considerations
 - Pre-paving Conference
- g. P-401 Bituminous Paving
 - ASTM D3666 Certified Lab
 - SuperPave Gyratory Compactor instead of Marshall Mix
- h. P-610 Concrete
 - ASR Testing (ASTM C1260 and C1567)

PHASING:

- a. Phase I (145 calendar days)
 - Phase IA – Relocation of 23L Threshold (1 calendar day)
 - Phase IB – Demo, milling, paving, underdrain, grading (102 calendar days)
 - Phase IC – Installation of electrical items, ALSF-2 work (58 calendar days)
- b. Phase II (86 calendar days)
 - Phase II cannot begin until Phase IB is complete
 - Runway will be closed for the duration of this phase

- Phase IIA - Demo, milling, paving, underdrain, grading (52 calendar days)
- Phase IIB – Installation of electrical items (31 calendar days)
- Phase IIC – Drainage improvements on Taxiway M (14 calendar days)
- c. Phase III (14 calendar days)
 - Grooving & painting work
- d. Phase IV (7 calendar days)
 - Signage work on Taxiway A
 - To be completed concurrently with Phase IB

SAFETY AND SECURITY:

- a. OPERATIONAL SAFETY ON AIRPORTS DURING CONSTRUCTION ACTIVITIES, General Requirement 01030, “Airport Project Procedures”
 - Construction Safety Phasing Plan (CSPP) to be provided in Addendum 1
 - Contractor is responsible for preparing a Safety Plan Compliance Document as stated in the General Provisions, paragraph 80-04.1.
- b. Security & Badging Requirements

WAGE RATES:

- a. Davis Bacon Wage Rates – Attachment to the General Provisions – will be updated by Addendum if necessary

DISCUSSION/QUESTIONS

1. *Some differences from previous package:*
 - a. *Underdrain will be installed in trench separate from the runway edge light trench*
 - b. *Two inlets (D60 & 61) will be converted to manholes and retrofitted with a spread footing foundation*
 - c. *No Engineer’s trailer is required*
2. *Question was asked about disposal of slurry waste from milling operation. Documents currently require contractor to dispose of offsite in an environmentally responsible manner. Contractors are going to look into alternative options and provide more information to PTAA/Baker.*
3. *The spread footing for the two existing inlets along the runway will not have anchors as in previous projects. Just a spread footing.*
4. *Question was asked concerning durations. If Phase I is finished early, can the contractor move to Phase II right away. The answer given by PTAA was that as long as they are given ample notice to coordinate with airlines and the public, that shouldn’t be a problem.*
5. *The follow up question to #4 was that if Phase I is finished early, can those days be rolled over into Phase II. The answer to that is no. The runway closure needs to be as limited as possible. Phase II will remain the number of calendar days as shown on the plan. Liquidated damages will apply to any days that are need beyond the calendar days for Phase I or Phase II as shown on the plans.*

6. See below for contact info for DBE company:



Pre-bid Meeting Sign-in

PIEDMONT TRIAD INTERNATIONAL AIRPORT

Runway 5R-23L Rehabilitation Project

November 9, 2017 @ 10:00 am
Stanley Frank Board Room

Name	Affiliation	Phone	Email
Heather Leopardi	Michael Baker	4122696407	hleopardi@mbakerintl.com
Lisa Elmore	PTAA	336-665-5639	elmorel@gsoair.org
Alex Rosser	PTAA	336-665-5600	rossera@gsoair.org
NICK RYAN	ARORA	610-459-7929	nryan@aroraengineers.com
Ken Weedon & Assoc. Inc.	Ken Weedon & Assoc. Inc.	919.871.5815	kenweeth-weedon@kwpblm.com
MARIKO DJUKIC	THOMPSON ARNIZ	336-706-3593	MDJUKIC@ATTC.COM
JESSIE BOGUE	CEDAR PEAKS	919-710-5734	jbogue.cedarpeaks@gmail.com
Larry D Pierce	Cedar Peaks	919 691 3616	lpierce.cedarpeaks@gmail.com
Vivian Goff	East Coast Construction Services	336.822.2803	vivian@eccseic.com
Rob Stafford	Sharpe Brothers	336-235-2756	rob.stafford@sharpebrosvg.com
Chris Bishop	PTAA	336 665 5625	bishopc@gsoair.org

NOTES

1. UNDERDRAIN AND STORM DRAINAGE PIPE NOT SHOWN FOR CLARITY.
2. SLOPE TOP OF SLAB TO MATCH SHOULDER GRADING. VARY SLAB THICKNESS AS NEEDED.
3. ADJUST BAR SPACING AND CUT BARS, AS NEEDED, TO ACCOMMODATE MANHOLE OPENINGS.
4. INSTALL NEW MANHOLE STEPS IN LINE WITH STEPS IN EXISTING BRICK STRUCTURE
5. USE P-610 CONCRETE WITH A MINIMUM COMPRESSIVE STRENGTH, $f_c=4,000$ PSI AT 28 DAYS.

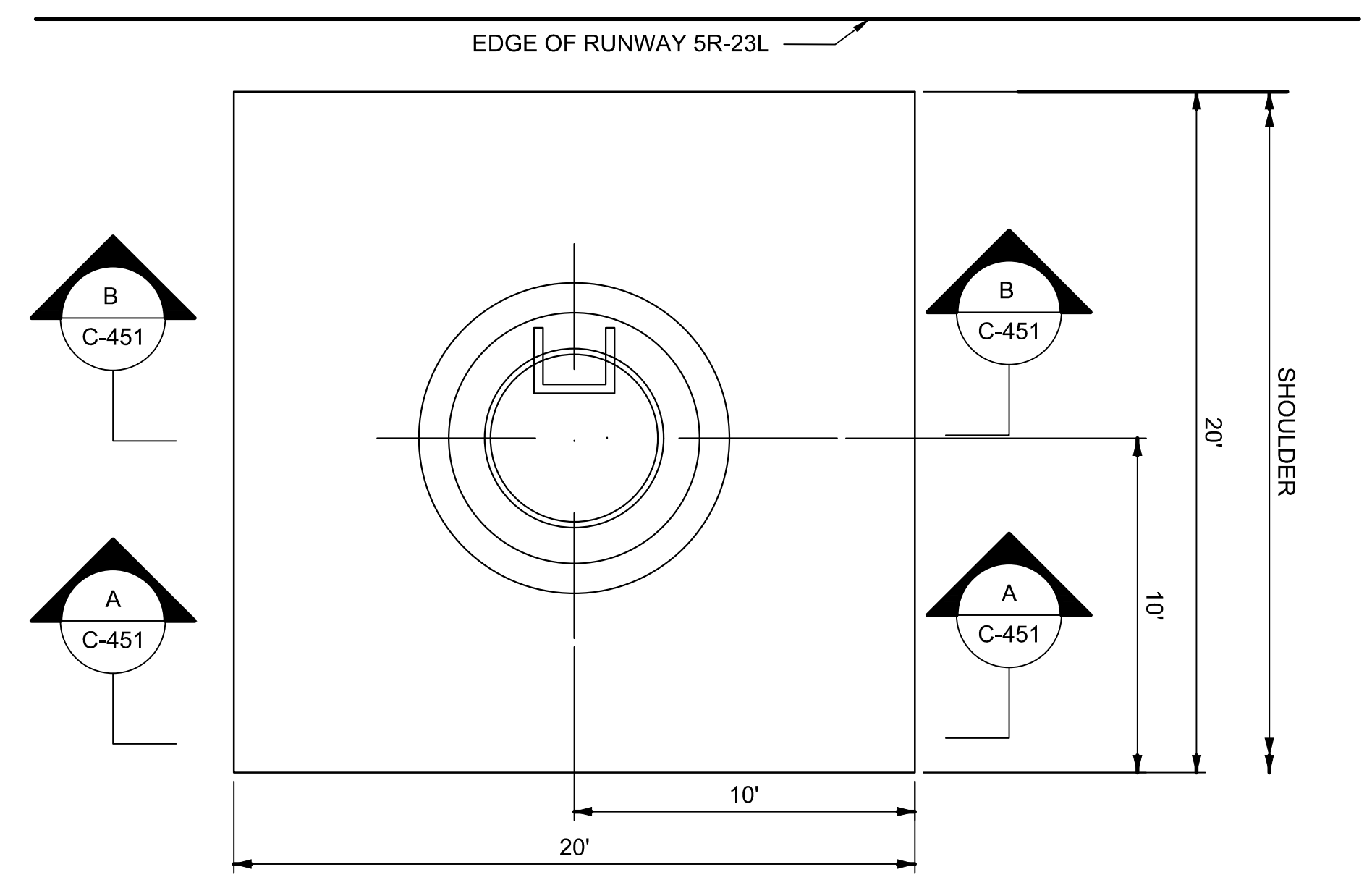

PLAN - COVER SLAB
 NTS

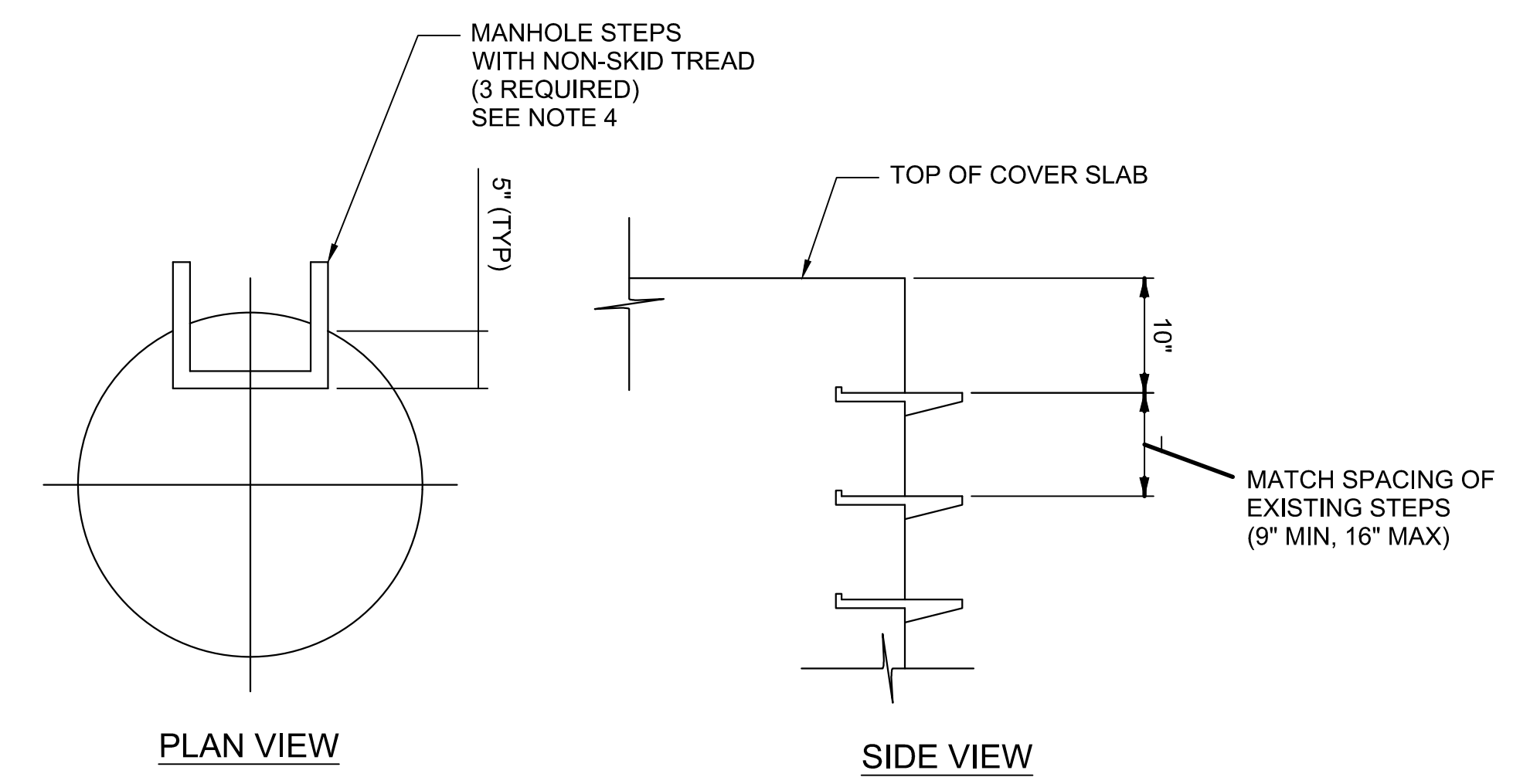

MANHOLE STEP CONFIGURATION
 NTS

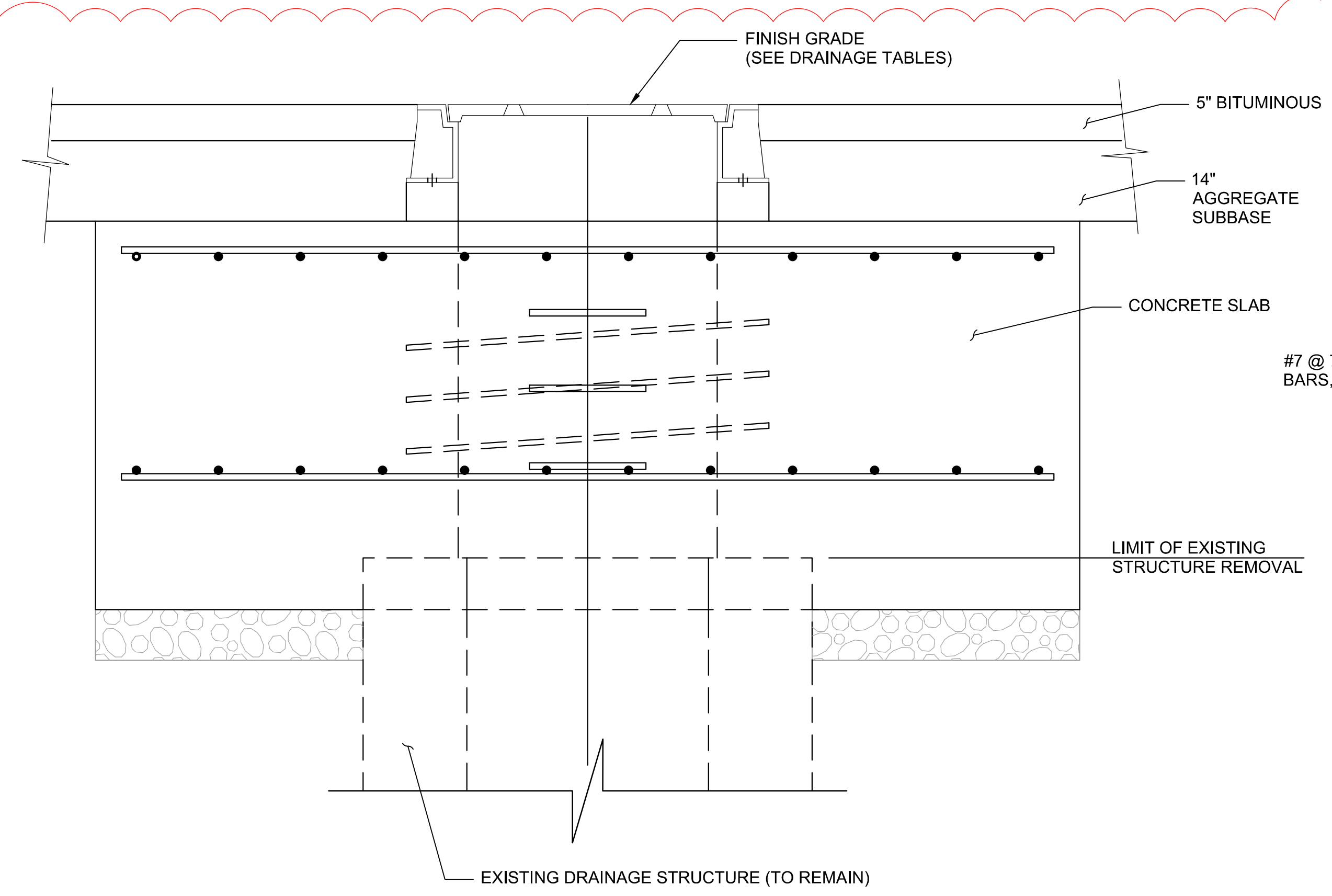

SECTION A-A
 NTS

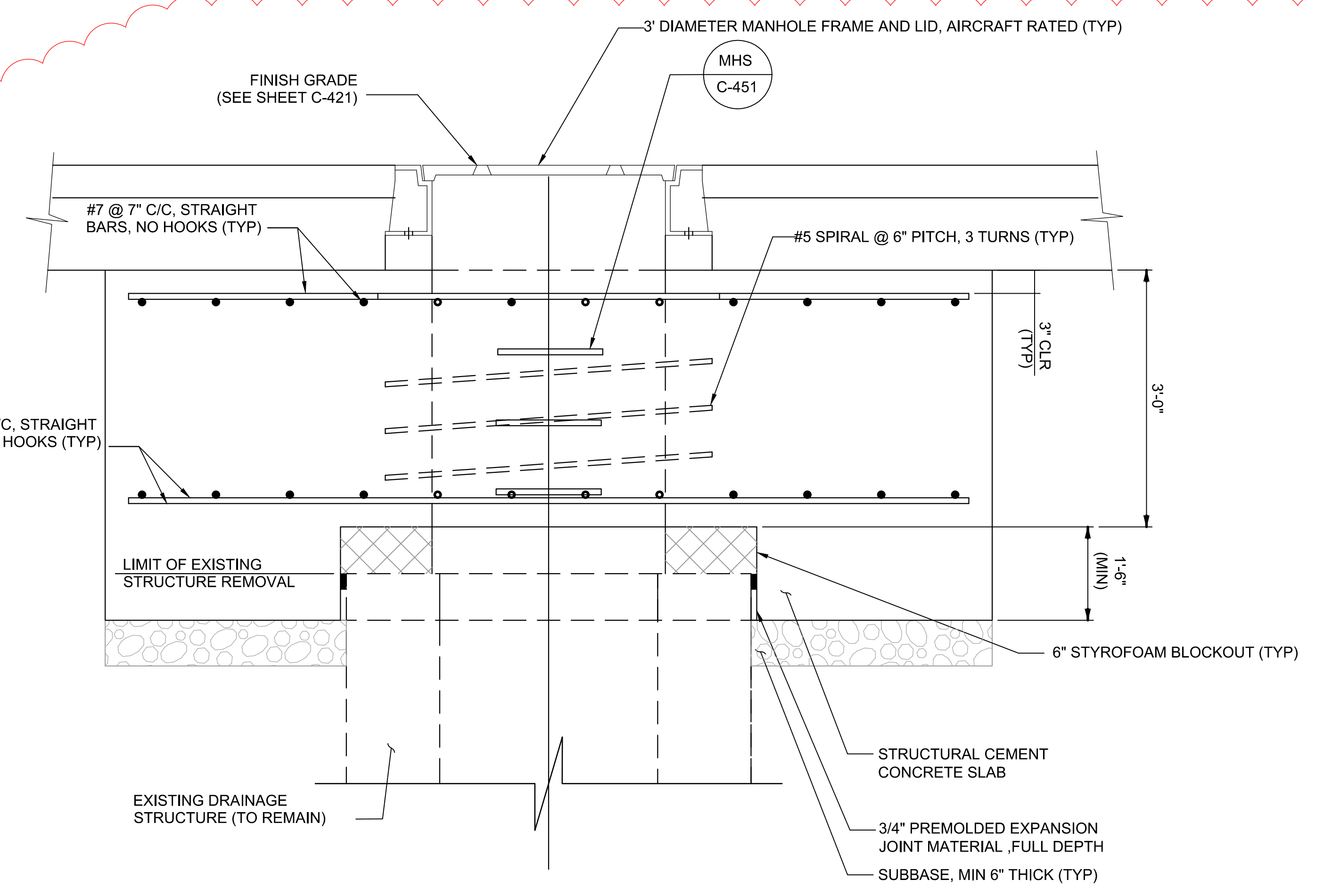

SECTION B-B
 NTS

STRUCTURE MODIFICATION
 NTS

1
 C-404

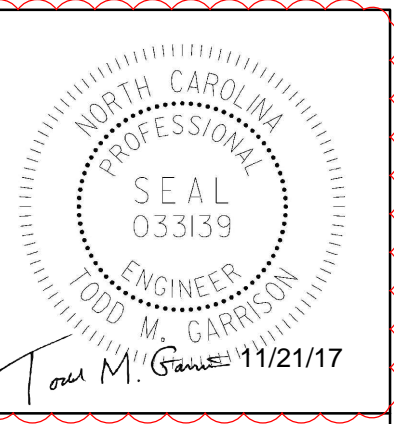

GHJ GHJ
 DESIGNED DRAWN
 DG TMG
 CHECKED APPROVED

Michael Baker INTERNATIONAL
 www.mbakertntl.com
 MICHAEL BAKER ENGINEERING, INC.
 200 Centreport Dr.
 Suite 350
 Greensboro, NC 27409
 OFC: (336) 931-1500
 FAX: (336) 931-1501

DATE: NOVEMBER 1, 2017
 SCALE: AS SHOWN

SHEET
C-451

REVISIONS			
NO.	DATE	BY	DESCRIPTION
1	11/21/17	DG	ADDENDUM 1

	OFFSET LEFT	110' LEFT (TURF)	SHOULDER EDGE LEFT (TURF)	SHOULDER EDGE LEFT (PAVEMENT)	75' LEFT (SHOULDER)	75' LEFT (RUNWAY)	50' LEFT	25' LEFT	CENTERLINE	25' RIGHT	50' RIGHT	75' RIGHT (RUNWAY)	75' RIGHT (SHOULDER)	SHOULDER EDGE RIGHT (PAVEMENT)	SHOULDER EDGE RIGHT (TURF)	110' RIGHT (TURF)	OFFSET RIGHT
153+00																	
MATCH EXISTING	115.10																120.24
EXISTING ELEV		884.36	884.57	884.57	885.66	885.66	886.06	886.44	886.76	886.42	886.05	885.63	885.63	884.62	884.62	884.56	
PROPOSED ELEV		884.16	884.66	884.78	885.94	885.94	886.31	886.68	887.05	886.69	886.34	885.98	885.98	884.99	884.86	884.36	
MILLED ELEV				884.53	885.61	885.41	885.81	886.18	886.51	886.17	885.80	885.38	885.59	884.58			
MILLED DEPTH (IN)				0.50	0.50	3.00	3.01	3.15	3.00	3.00	3.00	3.00	0.50	0.50			
PAVEMENT DEPTH (IN)				3.10	3.92	6.42	6.00	6.00	6.50	6.33	6.40	7.22	4.72	4.91			
TOP LIFT (IN)				2.00	2.00	2.50	2.50	2.50	2.50	2.50	2.50	2.50	2.00	2.00			
LIFT						2.50	2.50	2.50	2.50	2.50	2.50	2.50					
VARIABLE DEPTH LIFT (IN)				1.10	1.92	1.42	1.00	1.00	1.50	1.33	1.40	2.22	2.72	2.91			
153+25																	
MATCH EXISTING	115.46																114.59
EXISTING ELEV		884.49	884.67	884.67	885.75	885.75	886.15	886.53	886.85	886.51	886.14	885.73	885.73	884.70	884.70	884.53	
PROPOSED ELEV		884.25	884.75	884.88	886.03	886.03	886.40	886.77	887.14	886.78	886.43	886.07	886.07	885.05	884.92	884.42	
MILLED ELEV				884.63	885.71	885.50	885.90	886.27	886.60	886.26	885.89	885.48	885.69	884.66			
MILLED DEPTH (IN)				0.50	0.50	3.00	3.04	3.08	3.00	3.00	3.00	3.00	0.50	0.50			
PAVEMENT DEPTH (IN)				2.93	3.85	6.35	6.00	6.00	6.50	6.30	6.36	7.08	4.58	4.66			
TOP LIFT (IN)				2.00	2.00	2.50	2.50	2.50	2.50	2.50	2.50	2.50	2.00	2.00			
LIFT						2.50	2.50	2.50	2.50	2.50	2.50	2.50					
VARIABLE DEPTH LIFT (IN)				0.93	1.85	1.35	1.00	1.00	1.50	1.30	1.36	2.08	2.58	2.66			
153+50																	
MATCH EXISTING	136.06																113.06
EXISTING ELEV		884.76	884.79	884.79	885.86	885.86	886.24	886.62	886.93	886.59	886.23	885.81	885.81	884.85	884.85	884.59	
PROPOSED ELEV		884.34	884.84	884.97	886.12	886.12	886.49	886.86	887.23	886.87	886.51	886.16	886.16	885.09	884.97	884.47	
MILLED ELEV				884.75	885.82	885.61	885.99	886.36	886.68	886.34	885.98	885.56	885.77	884.81			
MILLED DEPTH (IN)				0.50	0.50	3.00	3.09	3.17	3.00	3.00	3.00	3.00	0.50	0.50			
PAVEMENT DEPTH (IN)				2.59	3.59	6.09	6.00	6.00	6.63	6.31	6.43	7.13	4.63	3.43			
TOP LIFT (IN)				2.00	2.00	2.50	2.50	2.50	2.50	2.50	2.50	2.50	2.00	2.00			
LIFT						2.50	2.50	2.50	2.50	2.50	2.50	2.50					
VARIABLE DEPTH LIFT (IN)				0.59	1.59	1.09	1.00	1.00	1.63	1.31	1.43	2.13	2.63	1.43			
153+75																	
MATCH EXISTING	133.79																119.13
EXISTING ELEV		884.92	884.89	884.89	885.94	885.94	886.33	886.70	887.00	886.67	886.31	885.89	885.89	884.94	884.94	884.52	
PROPOSED ELEV		884.44	884.94	885.07	886.20	886.20	886.57	886.94	887.32	886.96	886.60	886.24	886.24	885.14	885.01	884.51	
MILLED ELEV				884.85	885.90	885.69	886.07	886.44	886.75	886.42	886.06	885.64	885.85	884.89			
MILLED DEPTH (IN)				0.50	0.50	3.00	3.09	3.01	3.00	3.00	3.00	3.00	0.50	0.50			
PAVEMENT DEPTH (IN)				2.64	3.61	6.11	6.00	6.00	6.73	6.50	6.50	7.28	4.78	2.91			
TOP LIFT (IN)				2.00	2.00	2.50	2.50	2.50	2.50	2.50	2.50	2.50	2.00	2.00			
LIFT						2.50	2.50	2.50	2.50	2.50	2.50	2.50					

VARIABLE DEPTH LIFT (IN)				0.64	1.61	1.11	1.00	1.00	1.73	1.50	1.50	2.28	2.78	0.91			
	OFFSET LEFT	110' LEFT (TURF)	SHOULDER EDGE LEFT (TURF)	SHOULDER EDGE LEFT (PAVEMENT)	75' LEFT (SHOULDER)	75' LEFT (RUNWAY)	50' LEFT	25' LEFT	CENTERLINE	25' RIGHT	50' RIGHT	75' RIGHT (RUNWAY)	75' RIGHT (SHOULDER)	SHOULDER EDGE RIGHT (PAVEMENT)	SHOULDER EDGE RIGHT (TURF)	110' RIGHT (TURF)	OFFSET RIGHT
154+00																	
MATCH EXISTING	127.28																115.63
EXISTING ELEV		884.83	885.01	885.01	886.03	886.03	886.42	886.80	887.11	886.76	886.40	885.99	885.99	884.99	884.99	884.77	
PROPOSED ELEV		884.55	885.05	885.17	886.29	886.29	886.66	887.03	887.40	887.05	886.69	886.33	886.33	885.18	885.06	884.56	
MILLED ELEV				884.97	885.99	885.78	886.16	886.53	886.86	886.51	886.15	885.74	885.95	884.94			
MILLED DEPTH (IN)				0.50	0.50	3.00	3.06	3.17	3.00	3.00	3.00	3.00	0.50	0.50			
PAVEMENT DEPTH (IN)				2.46	3.64	6.14	6.00	6.00	6.53	6.39	6.49	7.08	4.58	2.84			
TOP LIFT (IN)				2.00	2.00	2.50	2.50	2.50	2.50	2.50	2.50	2.50	2.00	2.00			
LIFT						2.50	2.50	2.50	2.50	2.50	2.50	2.50					
VARIABLE DEPTH LIFT (IN)				0.46	1.64	1.14	1.00	1.00	1.53	1.39	1.49	2.08	2.58	0.84			
154+25																	
MATCH EXISTING	132.89																114.03
EXISTING ELEV		884.98	885.08	885.08	886.11	886.11	886.50	886.87	887.19	886.84	886.48	886.06	886.06	885.09	885.09	884.74	
PROPOSED ELEV		884.65	885.15	885.28	886.38	886.38	886.75	887.12	887.49	887.13	886.78	886.42	886.42	885.25	885.12	884.62	
MILLED ELEV				885.04	886.06	885.86	886.25	886.62	886.94	886.59	886.23	885.81	886.02	885.05			
MILLED DEPTH (IN)				0.50	0.50	3.00	3.00	3.03	3.00	3.00	3.00	3.00	0.50	0.50			
PAVEMENT DEPTH (IN)				2.81	3.76	6.26	6.03	6.00	6.67	6.50	6.61	7.30	4.80	2.37			
TOP LIFT (IN)				2.00	2.00	2.50	2.50	2.50	2.50	2.50	2.50	2.50	2.00	2.00			
LIFT						2.50	2.50	2.50	2.50	2.50	2.50	2.50					
VARIABLE DEPTH LIFT (IN)				0.81	1.76	1.26	1.03	1.00	1.67	1.50	1.61	2.30	2.80	0.37			
154+50																	
MATCH EXISTING	140.26																120.04
EXISTING ELEV		885.10	885.17	885.17	886.19	886.19	886.58	886.94	887.26	886.93	886.56	886.17	886.17	885.15	885.15	884.99	
PROPOSED ELEV		884.75	885.25	885.38	886.46	886.46	886.84	887.21	887.58	887.22	886.87	886.51	886.51	885.33	885.20	884.70	
MILLED ELEV				885.13	886.14	885.94	886.33	886.69	887.01	886.68	886.31	885.92	886.12	885.11			
MILLED DEPTH (IN)				0.50	0.50	3.00	3.00	3.00	3.00	3.00	3.00	3.00	0.50	0.50			
PAVEMENT DEPTH (IN)				2.95	3.84	6.34	6.12	6.19	6.79	6.50	6.63	7.13	4.63	2.62			
TOP LIFT (IN)				2.00	2.00	2.50	2.50	2.50	2.50	2.50	2.50	2.50	2.00	2.00			
LIFT						2.50	2.50	2.50	2.50	2.50	2.50	2.50					
VARIABLE DEPTH LIFT (IN)				0.95	1.84	1.34	1.12	1.19	1.79	1.50	1.63	2.13	2.63	0.62			
154+75																	
MATCH EXISTING	147.18																131.30
EXISTING ELEV		885.18	885.25	885.25	886.25	886.25	886.65	887.01	887.33	887.00	886.64	886.23	886.23	885.21	885.21	885.09	
PROPOSED ELEV		884.86	885.36	885.48	886.55	886.55	886.92	887.29	887.67	887.31	886.96	886.60	886.60	885.41	885.28	884.78	

MILLED ELEV				885.21	886.21	886.00	886.40	886.76	887.08	886.75	886.39	885.98	886.19	885.17			
MILLED DEPTH (IN)				0.50	0.50	3.00	3.00	3.00	3.00	3.00	3.00	3.00	0.50	0.50			
PAVEMENT DEPTH (IN)				3.32	4.08	6.58	6.31	6.36	6.99	6.68	6.77	7.39	4.89	2.83			
TOP LIFT (IN)				2.00	2.00	2.50	2.50	2.50	2.50	2.50	2.50	2.50	2.00	2.00			
LIFT						2.50	2.50	2.50	2.50	2.50	2.50	2.50					
VARIABLE DEPTH LIFT (IN)				1.32	2.08	1.58	1.31	1.36	1.99	1.68	1.77	2.39	2.89	0.83			
155+00																	
	OFFSET LEFT	110' LEFT (TURF)	SHOULDER EDGE LEFT (TURF)	SHOULDER EDGE LEFT (PAVEMENT)	75' LEFT (SHOULDER)	75' LEFT (RUNWAY)	50' LEFT	25' LEFT	CENTERLINE	25' RIGHT	50' RIGHT	75' RIGHT (RUNWAY)	75' RIGHT (SHOULDER)	SHOULDER EDGE RIGHT (PAVEMENT)	SHOULDER EDGE RIGHT (TURF)	110' RIGHT (TURF)	OFFSET RIGHT
MATCH EXISTING	124.64																132.57
EXISTING ELEV		885.26	885.31	885.31	886.34	886.34	886.73	887.12	887.44	887.12	886.73	886.32	886.32	885.34	885.34	885.24	
PROPOSED ELEV		884.96	885.46	885.59	886.64	886.64	887.01	887.38	887.75	887.40	887.04	886.69	886.69	885.49	885.36	884.86	
MILLED ELEV				885.27	886.30	886.09	886.48	886.87	887.19	886.87	886.48	886.07	886.28	885.30			
MILLED DEPTH (IN)				0.50	0.50	3.00	3.00	3.00	3.00	3.00	3.00	3.00	0.50	0.50			
PAVEMENT DEPTH (IN)				3.78	4.10	6.60	6.35	6.20	6.79	6.33	6.75	7.37	4.87	2.22			
TOP LIFT (IN)				2.00	2.00	2.50	2.50	2.50	2.50	2.50	2.50	2.50	2.00	2.00			
LIFT						2.50	2.50	2.50	2.50	2.50	2.50	2.50					
VARIABLE DEPTH LIFT (IN)				1.78	2.10	1.60	1.35	1.20	1.79	1.33	1.75	2.37	2.87	0.22			
155+25																	
	OFFSET LEFT	110' LEFT (TURF)	SHOULDER EDGE LEFT (TURF)	SHOULDER EDGE LEFT (PAVEMENT)	75' LEFT (SHOULDER)	75' LEFT (RUNWAY)	50' LEFT	25' LEFT	CENTERLINE	25' RIGHT	50' RIGHT	75' RIGHT (RUNWAY)	75' RIGHT (SHOULDER)	SHOULDER EDGE RIGHT (PAVEMENT)	SHOULDER EDGE RIGHT (TURF)	110' RIGHT (TURF)	OFFSET RIGHT
MATCH EXISTING	118.28																121.64
EXISTING ELEV		885.31	885.36	885.36	886.43	886.43	886.83	887.22	887.51	887.19	886.82	886.42	886.42	885.37	885.37	885.20	
PROPOSED ELEV		885.07	885.57	885.69	886.73	886.73	887.10	887.47	887.84	887.49	887.13	886.78	886.78	885.57	885.44	884.94	
MILLED ELEV				885.31	886.38	886.18	886.58	886.97	887.26	886.94	886.57	886.17	886.38	885.33			
MILLED DEPTH (IN)				0.50	0.50	3.00	3.00	3.00	3.00	3.00	3.00	3.00	0.50	0.50			
PAVEMENT DEPTH (IN)				4.51	4.10	6.60	6.20	6.01	6.94	6.61	6.79	7.32	4.82	2.82			
TOP LIFT (IN)				2.00	2.00	2.50	2.50	2.50	2.50	2.50	2.50	2.50	2.00	2.00			
LIFT						2.50	2.50	2.50	2.50	2.50	2.50	2.50					
VARIABLE DEPTH LIFT (IN)				2.51	2.10	1.60	1.20	1.01	1.94	1.61	1.79	2.32	2.82	0.82			
155+50																	
	OFFSET LEFT	110' LEFT (TURF)	SHOULDER EDGE LEFT (TURF)	SHOULDER EDGE LEFT (PAVEMENT)	75' LEFT (SHOULDER)	75' LEFT (RUNWAY)	50' LEFT	25' LEFT	CENTERLINE	25' RIGHT	50' RIGHT	75' RIGHT (RUNWAY)	75' RIGHT (SHOULDER)	SHOULDER EDGE RIGHT (PAVEMENT)	SHOULDER EDGE RIGHT (TURF)	110' RIGHT (TURF)	OFFSET RIGHT
MATCH EXISTING	116.39																138.72
EXISTING ELEV		885.32	885.46	885.46	886.53	886.53	886.93	887.32	887.61	887.28	886.90	886.51	886.51	885.51	885.51	885.48	
PROPOSED ELEV		885.17	885.67	885.79	886.81	886.81	887.19	887.56	887.93	887.57	887.22	886.87	886.87	885.66	885.53	885.03	
MILLED ELEV				885.42	886.49	886.28	886.68	887.06	887.36	887.03	886.65	886.26	886.47	885.47			
MILLED DEPTH (IN)				0.50	0.50	3.00	3.00	3.12	3.00	3.00	3.00	3.00	0.50	0.50			
PAVEMENT DEPTH (IN)				4.54	3.89	6.39	6.09	6.00	6.81	6.49	6.83	7.24	4.74	2.25			
TOP LIFT (IN)				2.00	2.00	2.50	2.50	2.50	2.50	2.50	2.50	2.50	2.00	2.00			
LIFT						2.50	2.50	2.50	2.50	2.50	2.50	2.50					
VARIABLE DEPTH LIFT (IN)				2.54	1.89	1.39	1.09	1.00	1.81	1.49	1.83	2.24	2.74	0.25			

	OFFSET LEFT	110' LEFT (TURF)	SHOULDER EDGE LEFT (TURF)	SHOULDER EDGE LEFT (PAVEMENT)	75' LEFT (SHOULDER)	75' LEFT (RUNWAY)	50' LEFT	25' LEFT	CENTERLINE	25' RIGHT	50' RIGHT	75' RIGHT (RUNWAY)	75' RIGHT (SHOULDER)	SHOULDER EDGE RIGHT (PAVEMENT)	SHOULDER EDGE RIGHT (TURF)	110' RIGHT (TURF)	OFFSET RIGHT
155+75																	
MATCH EXISTING	115.86																126.42
EXISTING ELEV		885.50	885.57	885.57	886.62	886.62	887.01	887.37	887.68	887.35	886.98	886.59	886.59	885.58	885.58	885.52	
PROPOSED ELEV		885.27	885.77	885.90	886.90	886.90	887.27	887.64	888.02	887.66	887.31	886.95	886.95	885.78	885.66	885.16	
MILLED ELEV				885.53	886.58	886.37	886.76	887.12	887.43	887.10	886.73	886.34	886.55	885.54			
MILLED DEPTH (IN)				0.50	0.50	3.00	3.00	3.00	3.00	3.00	3.00	3.00	0.50	0.50			
PAVEMENT DEPTH (IN)				4.43	3.81	6.31	6.19	6.30	7.04	6.70	6.94	7.32	4.82	2.94			
TOP LIFT (IN)				2.00	2.00	2.50	2.50	2.50	2.50	2.50	2.50	2.50	2.00	2.00			
LIFT						2.50	2.50	2.50	2.50	2.50	2.50	2.50					
VARIABLE DEPTH LIFT (IN)				2.43	1.81	1.31	1.19	1.30	2.04	1.70	1.94	2.32	2.82	0.94			
156+00																	
MATCH EXISTING	117.51																124.33
EXISTING ELEV		885.58	885.70	885.70	886.68	886.68	887.09	887.46	887.78	887.46	887.08	886.72	886.72	885.72	885.72	885.75	
PROPOSED ELEV		885.37	885.87	885.99	886.99	886.99	887.36	887.73	888.10	887.75	887.40	887.04	887.04	885.91	885.79	885.29	
MILLED ELEV				885.65	886.64	886.43	886.84	887.21	887.53	887.21	886.83	886.47	886.68	885.67			
MILLED DEPTH (IN)				0.50	0.50	3.00	3.00	3.00	3.00	3.00	3.00	3.00	0.50	0.50			
PAVEMENT DEPTH (IN)				4.03	4.15	6.65	6.29	6.30	6.88	6.52	6.86	6.92	4.42	2.86			
TOP LIFT (IN)				2.00	2.00	2.50	2.50	2.50	2.50	2.50	2.50	2.50	2.00	2.00			
LIFT						2.50	2.50	2.50	2.50	2.50	2.50	2.50					
VARIABLE DEPTH LIFT (IN)				2.03	2.15	1.65	1.29	1.30	1.88	1.52	1.86	1.92	2.42	0.86			
156+25																	
MATCH EXISTING	121.39																145.16
EXISTING ELEV		885.71	885.75	885.75	886.70	886.70	887.16	887.54	887.86	887.55	887.17	886.76	886.76	885.76	885.76	885.73	
PROPOSED ELEV		885.45	885.95	886.07	887.08	887.08	887.45	887.82	888.19	887.84	887.49	887.13	887.13	886.02	885.89	885.39	
MILLED ELEV				885.71	886.66	886.45	886.91	887.29	887.61	887.30	886.92	886.51	886.71	885.72			
MILLED DEPTH (IN)				0.50	0.50	3.00	3.00	3.00	3.00	3.00	3.00	3.00	0.50	0.50			
PAVEMENT DEPTH (IN)				4.37	5.01	7.51	6.46	6.31	6.98	6.50	6.79	7.52	5.02	3.64			
TOP LIFT (IN)				2.00	2.00	2.50	2.50	2.50	2.50	2.50	2.50	2.50	2.00	2.00			
LIFT						2.50	2.50	2.50	2.50	2.50	2.50	2.50					
VARIABLE DEPTH LIFT (IN)				2.37	3.01	2.51	1.46	1.31	1.98	1.50	1.79	2.52	3.02	1.64			
156+50																	
MATCH EXISTING	121.05																147.09
EXISTING ELEV		885.84	885.84	885.84	886.82	886.82	887.27	887.65	887.96	887.63	887.26	886.83	886.83	885.79	885.79	885.76	
PROPOSED ELEV		885.53	886.03	886.16	887.16	887.16	887.53	887.91	888.28	887.93	887.57	887.22	887.22	886.12	886.00	885.50	
MILLED ELEV				885.80	886.78	886.57	887.02	887.40	887.71	887.38	887.01	886.58	886.79	885.75			
MILLED DEPTH (IN)				0.50	0.50	3.00	3.00	3.00	3.00	3.00	3.00	3.00	0.50	0.50			

PAVEMENT DEPTH (IN)				4.32	4.62	7.12	6.23	6.04	6.83	6.58	6.73	7.65	5.15	4.44			
TOP LIFT (IN)				2.00	2.00	2.50	2.50	2.50	2.50	2.50	2.50	2.50	2.00	2.00			
LIFT						2.50	2.50	2.50	2.50	2.50	2.50	2.50					
VARIABLE DEPTH LIFT (IN)				2.32	2.62	2.12	1.23	1.04	1.83	1.58	1.73	2.65	3.15	2.44			

	OFFSET LEFT	110' LEFT (TURF)	SHOULDER EDGE LEFT (TURF)	SHOULDER EDGE LEFT (PAVEMENT)	75' LEFT (SHOULDER)	75' LEFT (RUNWAY)	50' LEFT	25' LEFT	CENTERLINE	25' RIGHT	50' RIGHT	75' RIGHT (RUNWAY)	75' RIGHT (SHOULDER)	SHOULDER EDGE RIGHT (PAVEMENT)	SHOULDER EDGE RIGHT (TURF)	110' RIGHT (TURF)	OFFSET RIGHT
--	-------------	------------------	---------------------------	-------------------------------	---------------------	-------------------	----------	----------	------------	-----------	-----------	--------------------	----------------------	--------------------------------	----------------------------	-------------------	--------------

156+75

MATCH EXISTING	127.38																124.28
EXISTING ELEV		885.97	885.94	885.94	886.98	886.98	887.40	887.75	888.07	887.74	887.38	886.97	886.97	885.92	885.92	885.84	
PROPOSED ELEV		885.61	886.11	886.24	887.25	887.25	887.62	887.99	888.37	888.01	887.66	887.31	887.31	886.23	886.10	885.60	
MILLED ELEV				885.90	886.94	886.73	887.12	887.49	887.82	887.49	887.13	886.72	886.93	885.88			
MILLED DEPTH (IN)				0.50	0.50	3.00	3.31	3.05	3.00	3.00	3.00	3.00	0.50	0.50			
PAVEMENT DEPTH (IN)				4.04	3.68	6.18	6.00	6.00	6.53	6.33	6.43	7.08	4.58	4.14			
TOP LIFT (IN)				2.00	2.00	2.50	2.50	2.50	2.50	2.50	2.50	2.50	2.00	2.00			
LIFT						2.50	2.50	2.50	2.50	2.50	2.50	2.50					
VARIABLE DEPTH LIFT (IN)				2.04	1.68	1.18	1.00	1.00	1.53	1.33	1.43	2.08	2.58	2.14			

	OFFSET LEFT	110' LEFT (TURF)	SHOULDER EDGE LEFT (TURF)	SHOULDER EDGE LEFT (PAVEMENT)	75' LEFT (SHOULDER)	75' LEFT (RUNWAY)	50' LEFT	25' LEFT	CENTERLINE	25' RIGHT	50' RIGHT	75' RIGHT (RUNWAY)	75' RIGHT (SHOULDER)	SHOULDER EDGE RIGHT (PAVEMENT)	SHOULDER EDGE RIGHT (TURF)	110' RIGHT (TURF)	OFFSET RIGHT
--	-------------	------------------	---------------------------	-------------------------------	---------------------	-------------------	----------	----------	------------	-----------	-----------	--------------------	----------------------	--------------------------------	----------------------------	-------------------	--------------

157+00

MATCH EXISTING	135.09																149.51
EXISTING ELEV		886.17	886.04	886.04	887.10	887.10	887.53	887.91	888.20	887.91	887.51	887.10	887.10	886.05	886.05	886.01	
PROPOSED ELEV		885.70	886.20	886.32	887.34	887.34	887.71	888.08	888.45	888.10	887.75	887.40	887.40	886.33	886.20	885.70	
MILLED ELEV				886.00	887.06	886.84	887.21	887.58	887.95	887.60	887.25	886.85	887.05	886.01			
MILLED DEPTH (IN)				0.50	0.50	3.15	3.89	3.99	3.00	3.68	3.09	3.00	0.50	0.50			
PAVEMENT DEPTH (IN)				3.84	3.35	6.00	6.00	6.00	6.11	6.00	6.00	6.63	4.13	3.82			
TOP LIFT (IN)				2.00	2.00	2.50	2.50	2.50	2.50	2.50	2.50	2.50	2.00	2.00			
LIFT						2.50	2.50	2.50	2.50	2.50	2.50	2.50					
VARIABLE DEPTH LIFT (IN)				1.84	1.35	1.00	1.00	1.00	1.11	1.00	1.00	1.63	2.13	1.82			

	OFFSET LEFT	110' LEFT (TURF)	SHOULDER EDGE LEFT (TURF)	SHOULDER EDGE LEFT (PAVEMENT)	75' LEFT (SHOULDER)	75' LEFT (RUNWAY)	50' LEFT	25' LEFT	CENTERLINE	25' RIGHT	50' RIGHT	75' RIGHT (RUNWAY)	75' RIGHT (SHOULDER)	SHOULDER EDGE RIGHT (PAVEMENT)	SHOULDER EDGE RIGHT (TURF)	110' RIGHT (TURF)	OFFSET RIGHT
--	-------------	------------------	---------------------------	-------------------------------	---------------------	-------------------	----------	----------	------------	-----------	-----------	--------------------	----------------------	--------------------------------	----------------------------	-------------------	--------------

157+25

MATCH EXISTING	135.86																118.06
EXISTING ELEV		886.22	886.16	886.16	887.19	887.19	887.64	888.00	888.27	887.98	887.61	887.21	887.21	886.11	886.11	885.99	
PROPOSED ELEV		885.78	886.28	886.40	887.42	887.42	887.80	888.17	888.54	888.19	887.84	887.49	887.49	886.43	886.31	885.81	
MILLED ELEV				886.11	887.15	886.92	887.30	887.67	888.02	887.69	887.34	886.96	887.16	886.07			
MILLED DEPTH (IN)				0.50	0.50	3.21	4.06	3.96	3.00	3.51	3.27	3.00	0.50	0.50			
PAVEMENT DEPTH (IN)				3.48	3.29	6.00	6.00	6.00	6.22	6.00	6.00	6.37	3.87	4.40			
TOP LIFT (IN)				2.00	2.00	2.50	2.50	2.50	2.50	2.50	2.50	2.50	2.00	2.00			
LIFT						2.50	2.50	2.50	2.50	2.50	2.50	2.50					
VARIABLE DEPTH LIFT (IN)				1.48	1.29	1.00	1.00	1.00	1.22	1.00	1.00	1.37	1.87	2.40			

	OFFSET LEFT	110' LEFT (TURF)	SHOULDER EDGE LEFT (TURF)	SHOULDER EDGE LEFT (PAVEMENT)	75' LEFT (SHOULDER)	75' LEFT (RUNWAY)	50' LEFT	25' LEFT	CENTERLINE	25' RIGHT	50' RIGHT	75' RIGHT (RUNWAY)	75' RIGHT (SHOULDER)	SHOULDER EDGE RIGHT (PAVEMENT)	SHOULDER EDGE RIGHT (TURF)	110' RIGHT (TURF)	OFFSET RIGHT
--	-------------	------------------	---------------------------	-------------------------------	---------------------	-------------------	----------	----------	------------	-----------	-----------	--------------------	----------------------	--------------------------------	----------------------------	-------------------	--------------

157+50

MATCH EXISTING	144.51																109.84
EXISTING ELEV		886.24	886.26	886.26	887.29	887.29	887.73	888.11	888.38	888.09	887.70	887.29	887.29	886.28	886.28	885.95	
PROPOSED ELEV		885.86	886.36	886.49	887.51	887.51	887.88	888.26	888.63	888.28	887.93	887.58	887.58	886.54	886.41	885.91	
MILLED ELEV				886.22	887.25	887.01	887.38	887.76	888.13	887.78	887.43	887.04	887.25	886.24			
MILLED DEPTH (IN)				0.50	0.50	3.38	4.18	4.26	3.00	3.78	3.31	3.00	0.50	0.50			
PAVEMENT DEPTH (IN)				3.21	3.12	6.00	6.00	6.00	6.00	6.00	6.00	6.43	3.93	3.52			
TOP LIFT (IN)				2.00	2.00	2.50	2.50	2.50	2.50	2.50	2.50	2.50	2.00	2.00			
LIFT						2.50	2.50	2.50	2.50	2.50	2.50	2.50					
VARIABLE DEPTH LIFT (IN)				1.21	1.12	1.00	1.00	1.00	1.00	1.00	1.00	1.43	1.93	1.52			

	OFFSET LEFT	110' LEFT (TURF)	SHOULDER EDGE LEFT (TURF)	SHOULDER EDGE LEFT (PAVEMENT)	75' LEFT (SHOULDER)	75' LEFT (RUNWAY)	50' LEFT	25' LEFT	CENTERLINE	25' RIGHT	50' RIGHT	75' RIGHT (RUNWAY)	75' RIGHT (SHOULDER)	SHOULDER EDGE RIGHT (PAVEMENT)	SHOULDER EDGE RIGHT (TURF)	110' RIGHT (TURF)	OFFSET RIGHT
157+75																	
MATCH EXISTING	146.86																113.08
EXISTING ELEV		886.43	886.42	886.42	887.35	887.35	887.79	888.16	888.46	888.18	887.79	887.37	887.37	886.38	886.38	886.00	
PROPOSED ELEV		885.95	886.44	886.57	887.60	887.60	887.97	888.34	888.72	888.37	888.02	887.66	887.66	886.64	886.51	886.01	
MILLED ELEV				886.38	887.31	887.10	887.47	887.84	888.21	887.87	887.52	887.12	887.33	886.34			
MILLED DEPTH (IN)				0.50	0.50	3.02	3.79	3.75	3.00	3.76	3.28	3.00	0.50	0.50			
PAVEMENT DEPTH (IN)				2.23	3.48	6.00	6.00	6.00	6.07	6.00	6.00	6.52	4.02	3.61			
TOP LIFT (IN)				2.00	2.00	2.50	2.50	2.50	2.50	2.50	2.50	2.50	2.00	2.00			
LIFT						2.50	2.50	2.50	2.50	2.50	2.50	2.50					
VARIABLE DEPTH LIFT (IN)				0.23	1.48	1.00	1.00	1.00	1.07	1.00	1.00	1.52	2.02	1.61			

	OFFSET LEFT	110' LEFT (TURF)	SHOULDER EDGE LEFT (TURF)	SHOULDER EDGE LEFT (PAVEMENT)	75' LEFT (SHOULDER)	75' LEFT (RUNWAY)	50' LEFT	25' LEFT	CENTERLINE	25' RIGHT	50' RIGHT	75' RIGHT (RUNWAY)	75' RIGHT (SHOULDER)	SHOULDER EDGE RIGHT (PAVEMENT)	SHOULDER EDGE RIGHT (TURF)	110' RIGHT (TURF)	OFFSET RIGHT
158+00																	
MATCH EXISTING	140.34																129.25
EXISTING ELEV		886.46	886.47	886.47	887.43	887.43	887.87	888.24	888.56	888.26	887.86	887.42	887.42	886.46	886.46	886.34	
PROPOSED ELEV		886.04	886.54	886.66	887.69	887.69	888.06	888.43	888.80	888.45	888.10	887.75	887.75	886.74	886.62	886.12	
MILLED ELEV				886.43	887.38	887.18	887.56	887.93	888.30	887.95	887.60	887.17	887.38	886.42			
MILLED DEPTH (IN)				0.50	0.50	3.00	3.69	3.64	3.09	3.69	3.06	3.00	0.50	0.50			
PAVEMENT DEPTH (IN)				2.76	3.62	6.12	6.00	6.00	6.00	6.00	6.00	6.96	4.46	3.84			
TOP LIFT (IN)				2.00	2.00	2.50	2.50	2.50	2.50	2.50	2.50	2.50	2.00	2.00			
LIFT						2.50	2.50	2.50	2.50	2.50	2.50	2.50					
VARIABLE DEPTH LIFT (IN)				0.76	1.62	1.12	1.00	1.00	1.00	1.00	1.00	1.96	2.46	1.84			

	OFFSET LEFT	110' LEFT (TURF)	SHOULDER EDGE LEFT (TURF)	SHOULDER EDGE LEFT (PAVEMENT)	75' LEFT (SHOULDER)	75' LEFT (RUNWAY)	50' LEFT	25' LEFT	CENTERLINE	25' RIGHT	50' RIGHT	75' RIGHT (RUNWAY)	75' RIGHT (SHOULDER)	SHOULDER EDGE RIGHT (PAVEMENT)	SHOULDER EDGE RIGHT (TURF)	110' RIGHT (TURF)	OFFSET RIGHT
158+25																	
MATCH EXISTING	134.98																184.19
EXISTING ELEV		886.46	886.57	886.57	887.53	887.53	887.97	888.34	888.64	888.33	887.94	887.50	887.50	886.55	886.55	886.49	
PROPOSED ELEV		886.13	886.63	886.76	887.77	887.77	888.15	888.52	888.89	888.54	888.19	887.84	887.84	886.84	886.72	886.22	
MILLED ELEV				886.53	887.49	887.27	887.65	888.02	888.39	888.04	887.69	887.25	887.45	886.51			
MILLED DEPTH (IN)				0.50	0.50	3.11	3.86	3.81	3.03	3.41	3.03	3.00	0.50	0.50			
PAVEMENT DEPTH (IN)				2.71	3.39	6.00	6.00	6.00	6.00	6.00	6.00	7.15	4.65	4.01			
TOP LIFT (IN)				2.00	2.00	2.50	2.50	2.50	2.50	2.50	2.50	2.50	2.00	2.00			
LIFT						2.50	2.50	2.50	2.50	2.50	2.50	2.50					
VARIABLE DEPTH LIFT (IN)				0.71	1.39	1.00	1.00	1.00	1.00	1.00	1.00	2.15	2.65	2.01			

	OFFSET LEFT	110' LEFT (TURF)	SHOULDER EDGE LEFT (TURF)	SHOULDER EDGE LEFT (PAVEMENT)	75' LEFT (SHOULDER)	75' LEFT (RUNWAY)	50' LEFT	25' LEFT	CENTERLINE	25' RIGHT	50' RIGHT	75' RIGHT (RUNWAY)	75' RIGHT (SHOULDER)	SHOULDER EDGE RIGHT (PAVEMENT)	SHOULDER EDGE RIGHT (TURF)	110' RIGHT (TURF)	OFFSET RIGHT
158+50																	
MATCH EXISTING	147.44																192.53
EXISTING ELEV		886.61	886.74	886.74	887.66	887.66	888.08	888.48	888.77	888.47	888.06	887.66	887.66	886.70	886.70	886.55	
PROPOSED ELEV		886.23	886.73	886.85	887.86	887.86	888.23	888.61	888.98	888.63	888.28	887.93	887.93	886.95	886.82	886.32	
MILLED ELEV				886.68	887.62	887.36	887.73	888.11	888.48	888.13	887.78	887.41	887.62	886.66			
MILLED DEPTH (IN)				0.70	0.50	3.59	4.18	4.48	3.52	4.09	3.40	3.00	0.50	0.50			
PAVEMENT DEPTH (IN)				2.00	2.91	6.00	6.00	6.00	6.00	6.00	6.00	6.27	3.77	3.47			
TOP LIFT (IN)				2.00	2.00	2.50	2.50	2.50	2.50	2.50	2.50	2.50	2.00	2.00			
LIFT						2.50	2.50	2.50	2.50	2.50	2.50	2.50					
VARIABLE DEPTH LIFT (IN)				0.00	0.91	1.00	1.00	1.00	1.00	1.00	1.00	1.27	1.77	1.47			
158+75																	
MATCH EXISTING	134.93																139.71
EXISTING ELEV		886.80	886.83	886.83	887.75	887.75	888.19	888.57	888.88	888.59	888.19	887.83	887.83	886.86	886.86	886.69	
PROPOSED ELEV		886.32	886.82	886.95	887.95	887.95	888.32	888.69	889.07	888.72	888.37	888.02	888.02	887.05	886.93	886.43	
MILLED ELEV				886.78	887.71	887.45	887.82	888.19	888.57	888.22	887.87	887.52	887.79	886.82			
MILLED DEPTH (IN)				0.55	0.50	3.63	4.48	4.52	3.81	4.50	3.91	3.73	0.50	0.50			
PAVEMENT DEPTH (IN)				2.00	2.87	6.00	6.00	6.00	6.00	6.00	6.00	6.00	2.77	2.82			
TOP LIFT (IN)				2.00	2.00	2.50	2.50	2.50	2.50	2.50	2.50	2.50	2.00	2.00			
LIFT						2.50	2.50	2.50	2.50	2.50	2.50	2.50					
VARIABLE DEPTH LIFT (IN)				0.00	0.87	1.00	1.00	1.00	1.00	1.00	1.00	1.00	0.77	0.82			
159+00																	
MATCH EXISTING	142.11																128.24
EXISTING ELEV		886.90	886.92	886.92	887.90	887.90	888.31	888.67	888.99	888.70	888.31	887.96	887.96	887.01	887.01	886.87	
PROPOSED ELEV		886.42	886.92	887.04	888.03	888.03	888.41	888.78	889.16	888.81	888.46	888.11	888.11	887.15	887.03	886.53	
MILLED ELEV				886.87	887.85	887.53	887.91	888.28	888.66	888.31	887.96	887.61	887.91	886.96			
MILLED DEPTH (IN)				0.50	0.50	4.32	4.79	4.70	4.02	4.67	4.19	4.18	0.50	0.50			
PAVEMENT DEPTH (IN)				2.02	2.18	6.00	6.00	6.00	6.00	6.00	6.00	6.00	2.32	2.27			
TOP LIFT (IN)				2.00	2.00	2.50	2.50	2.50	2.50	2.50	2.50	2.50	2.00	2.00			
LIFT						2.50	2.50	2.50	2.50	2.50	2.50	2.50					
VARIABLE DEPTH LIFT (IN)				0.02	0.18	1.00	1.00	1.00	1.00	1.00	1.00	1.00	0.32	0.27			
159+25																	
MATCH EXISTING	140.31																127.43
EXISTING ELEV		886.97	887.11	887.11	888.03	888.03	888.41	888.77	889.07	888.77	888.40	888.05	888.05	887.02	887.02		
PROPOSED ELEV		886.62	887.12	887.24	888.12	888.12	888.50	888.87	889.24	888.89	888.55	888.20	888.20	887.22	887.10		
MILLED ELEV				887.07	887.96	887.62	888.00	888.37	888.74	888.39	888.05	887.70	888.01	886.98			
MILLED DEPTH (IN)				0.50	0.94	4.94	5.01	4.75	3.98	4.52	4.28	4.27	0.50	0.50			

PAVEMENT DEPTH (IN)				2.11	2.00	6.00	6.00	6.00	6.00	6.00	6.00	6.00	2.23	2.93			
TOP LIFT (IN)				2.00	2.00	2.50	2.50	2.50	2.50	2.50	2.50	2.50	2.00	2.00			
LIFT						2.50	2.50	2.50	2.50	2.50	2.50	2.50					
VARIABLE DEPTH LIFT (IN)				0.11	0.00	1.00	1.00	1.00	1.00	1.00	1.00	1.00	0.23	0.93			
	OFFSET LEFT	110' LEFT (TURF)	SHOULDER EDGE LEFT (TURF)	SHOULDER EDGE LEFT (PAVEMENT)	75' LEFT (SHOULDER)	75' LEFT (RUNWAY)	50' LEFT	25' LEFT	CENTERLINE	25' RIGHT	50' RIGHT	75' RIGHT (RUNWAY)	75' RIGHT (SHOULDER)	SHOULDER EDGE RIGHT (PAVEMENT)	SHOULDER EDGE RIGHT (TURF)	110' RIGHT (TURF)	OFFSET RIGHT
159+50																	
MATCH EXISTING	116.03																111.68
EXISTING ELEV		886.84	887.39	887.39	888.15	888.15	888.51	888.85	889.17	888.87	888.48	888.07	888.07	887.23	887.23		
PROPOSED ELEV		886.86	887.36	887.49	888.21	888.21	888.58	888.96	889.33	888.98	888.63	888.29	888.29	887.46	887.33		
MILLED ELEV				887.32	888.04	887.71	888.08	888.46	888.83	888.48	888.13	887.79	888.03	887.19			
MILLED DEPTH (IN)				0.81	1.34	5.34	5.08	4.75	4.06	4.69	4.13	3.43	0.50	0.50			
PAVEMENT DEPTH (IN)				2.00	2.00	6.00	6.00	6.00	6.00	6.00	6.00	6.00	3.07	3.25			
TOP LIFT (IN)				2.00	2.00	2.50	2.50	2.50	2.50	2.50	2.50	2.50	2.00	2.00			
LIFT						2.50	2.50	2.50	2.50	2.50	2.50	2.50					
VARIABLE DEPTH LIFT (IN)				0.00	0.00	1.00	1.00	1.00	1.00	1.00	1.00	1.00	1.07	1.25			
	OFFSET LEFT	110' LEFT (TURF)	SHOULDER EDGE LEFT (TURF)	SHOULDER EDGE LEFT (PAVEMENT)	75' LEFT (SHOULDER)	75' LEFT (RUNWAY)	50' LEFT	25' LEFT	CENTERLINE	25' RIGHT	50' RIGHT	75' RIGHT (RUNWAY)	75' RIGHT (SHOULDER)	SHOULDER EDGE RIGHT (PAVEMENT)	SHOULDER EDGE RIGHT (TURF)	110' RIGHT (TURF)	OFFSET RIGHT
159+75																	
MATCH EXISTING	107.86																108.28
EXISTING ELEV			887.64	887.64	888.21	888.21	888.59	888.98	889.27	888.96	888.56	888.18	888.18	887.61			
PROPOSED ELEV			887.61	887.73	888.30	888.30	888.67	889.04	889.42	889.07	888.72	888.37	888.37	887.69			
MILLED ELEV				887.57	888.13	887.80	888.17	888.54	888.92	888.57	888.22	887.87	888.14	887.52			
MILLED DEPTH (IN)				0.88	0.91	4.91	5.07	5.21	4.20	4.67	4.03	3.66	0.50	1.05			
PAVEMENT DEPTH (IN)				2.00	2.00	6.00	6.00	6.00	6.00	6.00	6.00	6.00	6.00	2.84	2.00		
TOP LIFT (IN)				2.00	2.00	2.50	2.50	2.50	2.50	2.50	2.50	2.50	2.00	2.00			
LIFT						2.50	2.50	2.50	2.50	2.50	2.50	2.50					
VARIABLE DEPTH LIFT (IN)				0.00	0.00	1.00	1.00	1.00	1.00	1.00	1.00	1.00	0.84	0.00			
	OFFSET LEFT	110' LEFT (TURF)	SHOULDER EDGE LEFT (TURF)	SHOULDER EDGE LEFT (PAVEMENT)	75' LEFT (SHOULDER)	75' LEFT (RUNWAY)	50' LEFT	25' LEFT	CENTERLINE	25' RIGHT	50' RIGHT	75' RIGHT (RUNWAY)	75' RIGHT (SHOULDER)	SHOULDER EDGE RIGHT (PAVEMENT)	SHOULDER EDGE RIGHT (TURF)	110' RIGHT (TURF)	OFFSET RIGHT
160+00																	
MATCH EXISTING	100.26																122.51
EXISTING ELEV					888.30	888.30	888.68	889.06	889.37	889.07	888.65	888.29	888.29	887.82			
PROPOSED ELEV					888.38	888.38	888.76	889.13	889.51	889.16	888.81	888.46	888.46	887.91			
MILLED ELEV					888.22	887.88	888.26	888.63	889.01	888.66	888.31	887.96	888.25	887.74			
MILLED DEPTH (IN)					1.05	5.05	5.07	5.11	4.33	4.95	4.08	3.90	0.50	0.86			
PAVEMENT DEPTH (IN)					2.00	6.00	6.00	6.00	6.00	6.00	6.00	6.00	6.00	2.60	2.00		
TOP LIFT (IN)					2.00	2.50	2.50	2.50	2.50	2.50	2.50	2.50	2.00	2.00			
LIFT						2.50	2.50	2.50	2.50	2.50	2.50	2.50					
VARIABLE DEPTH LIFT (IN)					0.00	1.00	1.00	1.00	1.00	1.00	1.00	1.00	0.60	0.00			
	OFFSET LEFT	110' LEFT (TURF)	SHOULDER EDGE LEFT (TURF)	SHOULDER EDGE LEFT (PAVEMENT)	75' LEFT (SHOULDER)	75' LEFT (RUNWAY)	50' LEFT	25' LEFT	CENTERLINE	25' RIGHT	50' RIGHT	75' RIGHT (RUNWAY)	75' RIGHT (SHOULDER)	SHOULDER EDGE RIGHT (PAVEMENT)	SHOULDER EDGE RIGHT (TURF)	110' RIGHT (TURF)	OFFSET RIGHT
160+25																	

MATCH EXISTING	100.26																122.50
EXISTING ELEV					888.42	888.42	888.76	889.14	889.46	889.14	888.74	888.40	888.40	887.96	887.96		
PROPOSED ELEV					888.47	888.47	888.85	889.22	889.59	889.25	888.90	888.55	888.55	888.06	887.93		
MILLED ELEV				-0.17	888.30	887.97	888.35	888.72	889.09	888.75	888.40	888.05	888.36	887.89			
MILLED DEPTH (IN)				2.00	1.34	5.34	5.02	5.10	4.37	4.67	4.12	4.17	0.50	0.80			
PAVEMENT DEPTH (IN)				2.00	2.00	6.00	6.00	6.00	6.00	6.00	6.00	6.00	2.33	2.00			
TOP LIFT (IN)				2.00	2.00	2.50	2.50	2.50	2.50	2.50	2.50	2.50	2.00	2.00			
LIFT					2.50	2.50	2.50	2.50	2.50	2.50	2.50	2.50					
VARIABLE DEPTH LIFT (IN)				0.00	0.00	1.00	1.00	1.00	1.00	1.00	1.00	1.00	0.33	0.00			

	OFFSET LEFT	110' LEFT (TURF)	SHOULDER EDGE LEFT (TURF)	SHOULDER EDGE LEFT (PAVEMENT)	75' LEFT (SHOULDER)	75' LEFT (RUNWAY)	50' LEFT	25' LEFT	CENTERLINE	25' RIGHT	50' RIGHT	75' RIGHT (RUNWAY)	75' RIGHT (SHOULDER)	SHOULDER EDGE RIGHT (PAVEMENT)	SHOULDER EDGE RIGHT (TURF)	110' RIGHT (TURF)	OFFSET RIGHT
160+50																	
MATCH EXISTING	100.26																122.49
EXISTING ELEV					888.45	888.45	888.84	889.24	889.57	889.25	888.83	888.47	888.47	888.10	888.10		
PROPOSED ELEV					888.56	888.56	888.93	889.31	889.68	889.33	888.99	888.64	888.64	888.15	888.03		
MILLED ELEV				-0.17	888.39	888.06	888.43	888.81	889.18	888.83	888.49	888.14	888.42	887.99			
MILLED DEPTH (IN)				2.00	0.71	4.71	4.86	5.21	4.62	4.99	4.15	3.90	0.50	1.30			
PAVEMENT DEPTH (IN)				2.00	2.00	6.00	6.00	6.00	6.00	6.00	6.00	6.00	2.60	2.00			
TOP LIFT (IN)				2.00	2.00	2.50	2.50	2.50	2.50	2.50	2.50	2.50	2.00	2.00			
LIFT					2.50	2.50	2.50	2.50	2.50	2.50	2.50	2.50					
VARIABLE DEPTH LIFT (IN)				0.00	0.00	1.00	1.00	1.00	1.00	1.00	1.00	1.00	0.60	0.00			

	OFFSET LEFT	110' LEFT (TURF)	SHOULDER EDGE LEFT (TURF)	SHOULDER EDGE LEFT (PAVEMENT)	75' LEFT (SHOULDER)	75' LEFT (RUNWAY)	50' LEFT	25' LEFT	CENTERLINE	25' RIGHT	50' RIGHT	75' RIGHT (RUNWAY)	75' RIGHT (SHOULDER)	SHOULDER EDGE RIGHT (PAVEMENT)	SHOULDER EDGE RIGHT (TURF)	110' RIGHT (TURF)	OFFSET RIGHT
160+75																	
MATCH EXISTING	100.26																122.48
EXISTING ELEV					888.52	888.52	888.92	889.35	889.66	889.32	888.92	888.59	888.59	888.20	888.20		
PROPOSED ELEV					888.65	888.65	889.02	889.39	889.77	889.42	889.08	888.73	888.73	888.23	888.10		
MILLED ELEV					888.48	888.15	888.52	888.89	889.27	888.92	888.58	888.23	888.55	888.06			
MILLED DEPTH (IN)					0.55	4.55	4.75	5.41	4.67	4.80	4.18	4.29	0.50	1.67			
PAVEMENT DEPTH (IN)					2.00	6.00	6.00	6.00	6.00	6.00	6.00	6.00	2.21	2.00			
TOP LIFT (IN)					2.00	2.50	2.50	2.50	2.50	2.50	2.50	2.50	2.00	2.00			
LIFT					2.50	2.50	2.50	2.50	2.50	2.50	2.50	2.50	2.50				
VARIABLE DEPTH LIFT (IN)					0.00	1.00	1.00	1.00	1.00	1.00	1.00	1.00	0.21	0.00			

	OFFSET LEFT	110' LEFT (TURF)	SHOULDER EDGE LEFT (TURF)	SHOULDER EDGE LEFT (PAVEMENT)	75' LEFT (SHOULDER)	75' LEFT (RUNWAY)	50' LEFT	25' LEFT	CENTERLINE	25' RIGHT	50' RIGHT	75' RIGHT (RUNWAY)	75' RIGHT (SHOULDER)	SHOULDER EDGE RIGHT (PAVEMENT)	SHOULDER EDGE RIGHT (TURF)	110' RIGHT (TURF)	OFFSET RIGHT
161+00																	
MATCH EXISTING	100.26																122.47
EXISTING ELEV					888.65	888.65	888.99	889.42	889.74	889.41	889.01	888.68	888.68	888.25	888.25		
PROPOSED ELEV					888.73	888.73	889.11	889.48	889.86	889.51	889.16	888.82	888.82	888.29	888.16		
MILLED ELEV					888.57	888.23	888.61	888.98	889.36	889.01	888.66	888.32	888.63	888.12			
MILLED DEPTH (IN)					0.96	4.96	4.62	5.27	4.65	4.85	4.12	4.30	0.50	1.51			
PAVEMENT DEPTH (IN)					2.00	6.00	6.00	6.00	6.00	6.00	6.00	6.00	2.20	2.00			
TOP LIFT (IN)					2.00	2.50	2.50	2.50	2.50	2.50	2.50	2.50	2.00	2.00			
LIFT					2.50	2.50	2.50	2.50	2.50	2.50	2.50	2.50	2.50				
VARIABLE DEPTH LIFT (IN)					0.00	1.00	1.00	1.00	1.00	1.00	1.00	1.00	0.20	0.00			

	OFFSET LEFT	110' LEFT (TURF)	SHOULDER EDGE LEFT (TURF)	SHOULDER EDGE LEFT (PAVEMENT)	75' LEFT (SHOULDER)	75' LEFT (RUNWAY)	50' LEFT	25' LEFT	CENTERLINE	25' RIGHT	50' RIGHT	75' RIGHT (RUNWAY)	75' RIGHT (SHOULDER)	SHOULDER EDGE RIGHT (PAVEMENT)	SHOULDER EDGE RIGHT (TURF)	110' RIGHT (TURF)	OFFSET RIGHT
161+25																	
MATCH EXISTING	100.27																122.46
EXISTING ELEV					888.64	888.64	889.06	889.46	889.80	889.45	889.03	888.67	888.67	888.06	888.06		
PROPOSED ELEV					888.82	888.82	889.19	889.57	889.94	889.60	889.25	888.91	888.91	888.23	888.11		
MILLED ELEV					888.60	888.32	888.69	889.07	889.44	889.10	888.75	888.41	888.63	888.01			
MILLED DEPTH (IN)					0.50	3.82	4.34	4.72	4.22	4.24	3.36	3.16	0.50	0.50			
PAVEMENT DEPTH (IN)					2.68	6.00	6.00	6.00	6.00	6.00	6.00	6.00	3.34	2.59			
TOP LIFT (IN)					2.00	2.50	2.50	2.50	2.50	2.50	2.50	2.50	2.00	2.00			
LIFT						2.50	2.50	2.50	2.50	2.50	2.50	2.50					
VARIABLE DEPTH LIFT (IN)					0.68	1.00	1.00	1.00	1.00	1.00	1.00	1.00	1.34	0.59			
161+50																	
MATCH EXISTING	139.31																120.72
EXISTING ELEV		887.40	888.01	888.01	888.74	888.74	889.15	889.57	889.88	889.54	889.08	888.71	888.71	887.78	887.78		
PROPOSED ELEV		887.57	888.07	888.19	888.91	888.91	889.28	889.66	890.03	889.69	889.34	889.00	889.00	887.86	887.74		
MILLED ELEV				887.97	888.70	888.41	888.78	889.16	889.53	889.19	888.83	888.46	888.66	887.69			
MILLED DEPTH (IN)				0.50	0.50	4.00	4.46	4.98	4.19	4.23	3.00	3.00	0.50	1.07			
PAVEMENT DEPTH (IN)				2.65	2.50	6.00	6.00	6.00	6.00	6.00	6.18	6.48	3.98	2.00			
TOP LIFT (IN)				2.00	2.00	2.50	2.50	2.50	2.50	2.50	2.50	2.50	2.00	2.00			
LIFT						2.50	2.50	2.50	2.50	2.50	2.50	2.50					
VARIABLE DEPTH LIFT (IN)				0.65	0.50	1.00	1.00	1.00	1.00	1.00	1.18	1.48	1.98	0.00			
161+75																	
MATCH EXISTING	134.94																117.79
EXISTING ELEV		887.38	887.98	887.98	888.88	888.88	889.27	889.66	890.00	889.69	889.30	888.93	888.93	887.84	887.84		
PROPOSED ELEV		887.51	888.01	888.14	888.99	888.99	889.36	889.74	890.11	889.76	889.41	889.06	889.06	887.93	887.81		
MILLED ELEV				887.94	888.82	888.49	888.86	889.24	889.61	889.26	888.91	888.56	888.89	887.77			
MILLED DEPTH (IN)				0.50	0.75	4.75	4.87	5.11	4.70	5.16	4.67	4.42	0.50	0.85			
PAVEMENT DEPTH (IN)				2.34	2.00	6.00	6.00	6.00	6.00	6.00	6.00	6.00	2.08	2.00			
TOP LIFT (IN)				2.00	2.00	2.50	2.50	2.50	2.50	2.50	2.50	2.50	2.00	2.00			
LIFT						2.50	2.50	2.50	2.50	2.50	2.50	2.50					
VARIABLE DEPTH LIFT (IN)				0.34	0.00	1.00	1.00	1.00	1.00	1.00	1.00	1.00	0.08	0.00			
162+00																	
MATCH EXISTING	166.04																114.86
EXISTING ELEV		887.62	887.95	887.95	888.99	888.99	889.37	889.79	890.11	889.85	889.44	889.04	889.04	888.02	888.02		
PROPOSED ELEV		887.45	887.95	888.08	889.05	889.05	889.43	889.80	890.17	889.83	889.48	889.13	889.13	888.15	888.03		
MILLED ELEV				887.90	888.89	888.55	888.93	889.30	889.67	889.33	888.98	888.63	888.96	887.98			
MILLED DEPTH (IN)				0.50	1.22	5.22	5.29	5.81	5.17	6.24	5.60	4.93	0.93	0.50			

PAVEMENT DEPTH (IN)				2.09	2.00	6.00	6.00	6.00	6.00	6.00	6.00	6.00	2.00	2.11			
TOP LIFT (IN)				2.00	2.00	2.50	2.50	2.50	2.50	2.50	2.50	2.50	2.00	2.00			
LIFT						2.50	2.50	2.50	2.50	2.50	2.50	2.50					
VARIABLE DEPTH LIFT (IN)				0.09	0.00	1.00	1.00	1.00	1.00	1.00	1.00	1.00	0.00	0.11			

	OFFSET LEFT	110' LEFT (TURF)	SHOULDER EDGE LEFT (TURF)	SHOULDER EDGE LEFT (PAVEMENT)	75' LEFT (SHOULDER)	75' LEFT (RUNWAY)	50' LEFT	25' LEFT	CENTERLINE	25' RIGHT	50' RIGHT	75' RIGHT (RUNWAY)	75' RIGHT (SHOULDER)	SHOULDER EDGE RIGHT (PAVEMENT)	SHOULDER EDGE RIGHT (TURF)	110' RIGHT (TURF)	OFFSET RIGHT
--	-------------	------------------	---------------------------	-------------------------------	---------------------	-------------------	----------	----------	------------	-----------	-----------	--------------------	----------------------	--------------------------------	----------------------------	-------------------	--------------

162+25

MATCH EXISTING	118.12																113.86
EXISTING ELEV		887.67	887.94	887.94	889.04	889.04	889.44	889.85	890.17	889.86	889.50	889.08	889.08	888.10	888.10	887.79	
PROPOSED ELEV		887.47	887.97	888.09	889.12	889.12	889.49	889.87	890.24	889.89	889.54	889.19	889.19	888.23	888.11	887.61	
MILLED ELEV				887.90	888.95	888.62	888.99	889.37	889.74	889.39	889.04	888.69	888.03	888.06			
MILLED DEPTH (IN)				0.50	1.02	5.02	5.37	5.84	5.14	5.65	5.53	4.60	0.60	0.50			
PAVEMENT DEPTH (IN)				2.33	2.00	6.00	6.00	6.00	6.00	6.00	6.00	6.00	2.00	2.03			
TOP LIFT (IN)				2.00	2.00	2.50	2.50	2.50	2.50	2.50	2.50	2.50	2.00	2.00			
LIFT						2.50	2.50	2.50	2.50	2.50	2.50	2.50					
VARIABLE DEPTH LIFT (IN)				0.33	0.00	1.00	1.00	1.00	1.00	1.00	1.00	1.00	0.00	0.03			

	OFFSET LEFT	110' LEFT (TURF)	SHOULDER EDGE LEFT (TURF)	SHOULDER EDGE LEFT (PAVEMENT)	75' LEFT (SHOULDER)	75' LEFT (RUNWAY)	50' LEFT	25' LEFT	CENTERLINE	25' RIGHT	50' RIGHT	75' RIGHT (RUNWAY)	75' RIGHT (SHOULDER)	SHOULDER EDGE RIGHT (PAVEMENT)	SHOULDER EDGE RIGHT (TURF)	110' RIGHT (TURF)	OFFSET RIGHT
--	-------------	------------------	---------------------------	-------------------------------	---------------------	-------------------	----------	----------	------------	-----------	-----------	--------------------	----------------------	--------------------------------	----------------------------	-------------------	--------------

162+50

MATCH EXISTING	120.13																114.98
EXISTING ELEV		887.90	888.00	888.00	889.10	889.10	889.50	889.89	890.25	889.97	889.58	889.17	889.17	888.14	888.14	887.83	
PROPOSED ELEV		887.54	888.03	888.16	889.18	889.18	889.56	889.93	890.30	889.96	889.61	889.26	889.26	888.30	888.18	887.68	
MILLED ELEV				887.96	889.02	888.68	889.06	889.43	889.80	889.46	889.11	888.76	889.09	888.10			
MILLED DEPTH (IN)				0.50	0.95	4.95	5.34	5.54	5.37	6.22	5.64	4.91	0.91	0.50			
PAVEMENT DEPTH (IN)				2.41	2.00	6.00	6.00	6.00	6.00	6.00	6.00	6.00	2.00	2.44			
TOP LIFT (IN)				2.00	2.00	2.50	2.50	2.50	2.50	2.50	2.50	2.50	2.00	2.00			
LIFT						2.50	2.50	2.50	2.50	2.50	2.50	2.50					
VARIABLE DEPTH LIFT (IN)				0.41	0.00	1.00	1.00	1.00	1.00	1.00	1.00	1.00	0.00	0.44			

	OFFSET LEFT	110' LEFT (TURF)	SHOULDER EDGE LEFT (TURF)	SHOULDER EDGE LEFT (PAVEMENT)	75' LEFT (SHOULDER)	75' LEFT (RUNWAY)	50' LEFT	25' LEFT	CENTERLINE	25' RIGHT	50' RIGHT	75' RIGHT (RUNWAY)	75' RIGHT (SHOULDER)	SHOULDER EDGE RIGHT (PAVEMENT)	SHOULDER EDGE RIGHT (TURF)	110' RIGHT (TURF)	OFFSET RIGHT
--	-------------	------------------	---------------------------	-------------------------------	---------------------	-------------------	----------	----------	------------	-----------	-----------	--------------------	----------------------	--------------------------------	----------------------------	-------------------	--------------

162+75

MATCH EXISTING	120.59																123.92
EXISTING ELEV		887.85	888.08	888.08	889.15	889.15	889.56	889.95	890.30	890.00	889.63	889.20	889.20	888.14	888.14	887.93	
PROPOSED ELEV		887.60	888.10	888.23	889.25	889.25	889.62	889.99	890.37	890.02	889.67	889.33	889.33	888.32	888.20	887.70	
MILLED ELEV				888.03	889.08	888.75	889.12	889.49	889.87	889.52	889.17	888.83	889.16	888.10			
MILLED DEPTH (IN)				0.50	0.81	4.81	5.26	5.54	5.25	5.74	5.51	4.53	0.53	0.50			
PAVEMENT DEPTH (IN)				2.32	2.00	6.00	6.00	6.00	6.00	6.00	6.00	6.00	2.00	2.74			
TOP LIFT (IN)				2.00	2.00	2.50	2.50	2.50	2.50	2.50	2.50	2.50	2.00	2.00			
LIFT						2.50	2.50	2.50	2.50	2.50	2.50	2.50					
VARIABLE DEPTH LIFT (IN)				0.32	0.00	1.00	1.00	1.00	1.00	1.00	1.00	1.00	0.00	0.74			

	OFFSET LEFT	110' LEFT (TURF)	SHOULDER EDGE LEFT (TURF)	SHOULDER EDGE LEFT (PAVEMENT)	75' LEFT (SHOULDER)	75' LEFT (RUNWAY)	50' LEFT	25' LEFT	CENTERLINE	25' RIGHT	50' RIGHT	75' RIGHT (RUNWAY)	75' RIGHT (SHOULDER)	SHOULDER EDGE RIGHT (PAVEMENT)	SHOULDER EDGE RIGHT (TURF)	110' RIGHT (TURF)	OFFSET RIGHT
--	-------------	------------------	---------------------------	-------------------------------	---------------------	-------------------	----------	----------	------------	-----------	-----------	--------------------	----------------------	--------------------------------	----------------------------	-------------------	--------------

163+00

MATCH EXISTING	122.52																121.30
EXISTING ELEV		887.89	888.10	888.10	889.21	889.21	889.62	890.03	890.36	890.05	889.67	889.23	889.23	888.20	888.20	887.99	
PROPOSED ELEV		887.67	888.17	888.29	889.31	889.31	889.68	890.06	890.43	890.08	889.74	889.39	889.39	888.36	888.23	887.73	
MILLED ELEV				888.06	889.14	888.81	889.18	889.56	889.93	889.58	889.24	888.89	889.19	888.16			
MILLED DEPTH (IN)				0.50	0.74	4.74	5.17	5.68	5.18	5.58	5.13	4.10	0.50	0.50			
PAVEMENT DEPTH (IN)				2.79	2.00	6.00	6.00	6.00	6.00	6.00	6.00	6.00	6.00	2.40	2.37		
TOP LIFT (IN)				2.00	2.00	2.50	2.50	2.50	2.50	2.50	2.50	2.50	2.00	2.00			
LIFT						2.50	2.50	2.50	2.50	2.50	2.50	2.50					
VARIABLE DEPTH LIFT (IN)				0.79	0.00	1.00	1.00	1.00	1.00	1.00	1.00	1.00	0.40	0.37			

	OFFSET LEFT	110' LEFT (TURF)	SHOULDER EDGE LEFT (TURF)	SHOULDER EDGE LEFT (PAVEMENT)	75' LEFT (SHOULDER)	75' LEFT (RUNWAY)	50' LEFT	25' LEFT	CENTERLINE	25' RIGHT	50' RIGHT	75' RIGHT (RUNWAY)	75' RIGHT (SHOULDER)	SHOULDER EDGE RIGHT (PAVEMENT)	SHOULDER EDGE RIGHT (TURF)	110' RIGHT (TURF)	OFFSET RIGHT
163+25																	
MATCH EXISTING	118.73																120.44
EXISTING ELEV		887.94	888.16	888.16	889.22	889.22	889.65	890.04	890.40	890.11	889.68	889.24	889.24	888.19	888.19	887.99	
PROPOSED ELEV		887.71	888.21	888.34	889.38	889.38	889.75	890.12	890.50	890.15	889.80	889.46	889.46	888.40	888.27	887.78	
MILLED ELEV				888.11	889.18	888.88	889.25	889.62	890.00	889.65	889.30	888.96	889.20	888.15			
MILLED DEPTH (IN)				0.50	0.50	4.18	4.84	5.07	4.88	5.49	4.57	3.38	0.50	0.50			
PAVEMENT DEPTH (IN)				2.68	2.32	6.00	6.00	6.00	6.00	6.00	6.00	6.00	3.12	2.97			
TOP LIFT (IN)				2.00	2.00	2.50	2.50	2.50	2.50	2.50	2.50	2.50	2.00	2.00			
LIFT						2.50	2.50	2.50	2.50	2.50	2.50	2.50					
VARIABLE DEPTH LIFT (IN)				0.68	0.32	1.00	1.00	1.00	1.00	1.00	1.00	1.00	1.12	0.97			

	OFFSET LEFT	110' LEFT (TURF)	SHOULDER EDGE LEFT (TURF)	SHOULDER EDGE LEFT (PAVEMENT)	75' LEFT (SHOULDER)	75' LEFT (RUNWAY)	50' LEFT	25' LEFT	CENTERLINE	25' RIGHT	50' RIGHT	75' RIGHT (RUNWAY)	75' RIGHT (SHOULDER)	SHOULDER EDGE RIGHT (PAVEMENT)	SHOULDER EDGE RIGHT (TURF)	110' RIGHT (TURF)	OFFSET RIGHT
163+50																	
MATCH EXISTING	116.95																116.28
EXISTING ELEV		887.96	888.18	888.18	889.28	889.28	889.70	890.08	890.43	890.09	889.69	889.25	889.25	888.14	888.14	887.90	
PROPOSED ELEV		887.72	888.22	888.35	889.44	889.44	889.81	890.19	890.56	890.21	889.86	889.51	889.51	888.40	888.28	887.78	
MILLED ELEV				888.14	889.24	888.94	889.31	889.69	890.06	889.71	889.36	889.00	889.21	888.09			
MILLED DEPTH (IN)				0.50	0.50	4.05	4.65	4.74	4.42	4.47	3.98	3.00	0.50	0.50			
PAVEMENT DEPTH (IN)				2.44	2.45	6.00	6.00	6.00	6.00	6.00	6.00	6.07	3.57	3.70			
TOP LIFT (IN)				2.00	2.00	2.50	2.50	2.50	2.50	2.50	2.50	2.50	2.00	2.00			
LIFT						2.50	2.50	2.50	2.50	2.50	2.50	2.50					
VARIABLE DEPTH LIFT (IN)				0.44	0.45	1.00	1.00	1.00	1.00	1.00	1.00	1.07	1.57	1.70			

	OFFSET LEFT	110' LEFT (TURF)	SHOULDER EDGE LEFT (TURF)	SHOULDER EDGE LEFT (PAVEMENT)	75' LEFT (SHOULDER)	75' LEFT (RUNWAY)	50' LEFT	25' LEFT	CENTERLINE	25' RIGHT	50' RIGHT	75' RIGHT (RUNWAY)	75' RIGHT (SHOULDER)	SHOULDER EDGE RIGHT (PAVEMENT)	SHOULDER EDGE RIGHT (TURF)	110' RIGHT (TURF)	OFFSET RIGHT
163+75																	
MATCH EXISTING	134.09																114.60
EXISTING ELEV		887.93	888.20	888.20	889.34	889.34	889.74	890.11	890.44	890.09	889.71	889.29	889.29	888.12	888.12	887.78	
PROPOSED ELEV		887.73	888.23	888.35	889.47	889.47	889.84	890.22	890.59	890.23	889.88	889.53	889.53	888.40	888.28	887.78	
MILLED ELEV				888.16	889.30	888.97	889.34	889.72	890.09	889.73	889.38	889.03	889.25	888.08			
MILLED DEPTH (IN)				0.50	0.50	4.47	4.75	4.68	4.24	4.25	3.98	3.14	0.50	0.50			
PAVEMENT DEPTH (IN)				2.29	2.03	6.00	6.00	6.00	6.00	6.00	6.00	6.00	3.36	3.88			
TOP LIFT (IN)				2.00	2.00	2.50	2.50	2.50	2.50	2.50	2.50	2.50	2.00	2.00			
LIFT						2.50	2.50	2.50	2.50	2.50	2.50	2.50					
VARIABLE DEPTH LIFT (IN)				0.29	0.03	1.00	1.00	1.00	1.00	1.00	1.00	1.00	1.36	1.88			

	OFFSET LEFT	110' LEFT (TURF)	SHOULDER EDGE LEFT (TURF)	SHOULDER EDGE LEFT (PAVEMENT)	75' LEFT (SHOULDER)	75' LEFT (RUNWAY)	50' LEFT	25' LEFT	CENTERLINE	25' RIGHT	50' RIGHT	75' RIGHT (RUNWAY)	75' RIGHT (SHOULDER)	SHOULDER EDGE RIGHT (PAVEMENT)	SHOULDER EDGE RIGHT (TURF)	110' RIGHT (TURF)	OFFSET RIGHT
164+00																	
MATCH EXISTING	136.13																117.84
EXISTING ELEV		887.98	888.18	888.18	889.35	889.35	889.77	890.14	890.46	890.11	889.73	889.29	889.29	888.08	888.08	887.93	
PROPOSED ELEV		887.75	888.25	888.38	889.49	889.49	889.86	890.23	890.61	890.25	889.90	889.55	889.55	888.40	888.28	887.78	
MILLED ELEV				888.14	889.31	888.99	889.36	889.73	890.11	889.75	889.40	889.04	889.24	888.04			
MILLED DEPTH (IN)				0.50	0.50	4.34	4.89	4.85	4.30	4.29	4.01	3.00	0.50	0.50			
PAVEMENT DEPTH (IN)				2.80	2.16	6.00	6.00	6.00	6.00	6.00	6.00	6.14	3.64	4.43			
TOP LIFT (IN)				2.00	2.00	2.50	2.50	2.50	2.50	2.50	2.50	2.50	2.00	2.00			
LIFT						2.50	2.50	2.50	2.50	2.50	2.50	2.50					
VARIABLE DEPTH LIFT (IN)				0.80	0.16	1.00	1.00	1.00	1.00	1.00	1.00	1.14	1.64	2.43			
164+25																	
MATCH EXISTING	127.75																112.23
EXISTING ELEV		887.95	888.15	888.15	889.39	889.39	889.80	890.17	890.49	890.14	889.76	889.31	889.31	888.01	888.01	887.89	
PROPOSED ELEV		887.78	888.28	888.41	889.51	889.51	889.88	890.25	890.62	890.27	889.92	889.57	889.57	888.42	888.29	887.80	
MILLED ELEV				888.11	889.34	889.01	889.38	889.75	890.12	889.77	889.42	889.06	889.27	887.97			
MILLED DEPTH (IN)				0.50	0.52	4.52	5.09	5.07	4.39	4.45	4.04	3.00	0.50	0.50			
PAVEMENT DEPTH (IN)				3.55	2.00	6.00	6.00	6.00	6.00	6.00	6.00	6.06	3.56	5.44			
TOP LIFT (IN)				2.00	2.00	2.50	2.50	2.50	2.50	2.50	2.50	2.50	2.00	2.00			
LIFT						2.50	2.50	2.50	2.50	2.50	2.50	2.50					
VARIABLE DEPTH LIFT (IN)				1.55	0.00	1.00	1.00	1.00	1.00	1.00	1.00	1.06	1.56	3.44			
164+50																	
MATCH EXISTING	118.06																112.12
EXISTING ELEV		888.05	888.16	888.16	889.41	889.41	889.83	890.20	890.52	890.17	889.78	889.35	889.35	888.13	888.13	887.93	
PROPOSED ELEV		887.82	888.32	888.44	889.53	889.53	889.90	890.27	890.64	890.29	889.94	889.59	889.59	888.45	888.32	887.82	
MILLED ELEV				888.12	889.36	889.03	889.40	889.77	890.14	889.79	889.44	889.09	889.31	888.09			
MILLED DEPTH (IN)				0.50	0.64	4.64	5.18	5.19	4.52	4.59	4.12	3.18	0.50	0.50			
PAVEMENT DEPTH (IN)				3.86	2.00	6.00	6.00	6.00	6.00	6.00	6.00	6.00	3.32	4.27			
TOP LIFT (IN)				2.00	2.00	2.50	2.50	2.50	2.50	2.50	2.50	2.50	2.00	2.00			
LIFT						2.50	2.50	2.50	2.50	2.50	2.50	2.50					
VARIABLE DEPTH LIFT (IN)				1.86	0.00	1.00	1.00	1.00	1.00	1.00	1.00	1.00	1.32	2.27			
164+75																	
MATCH EXISTING	113.93																112.13
EXISTING ELEV		887.99	888.21	888.21	889.40	889.40	889.85	890.20	890.53	890.19	889.80	889.39	889.39	888.21	888.21	887.96	
PROPOSED ELEV		887.85	888.35	888.47	889.55	889.55	889.92	890.29	890.66	890.31	889.96	889.61	889.61	888.48	888.35	887.85	
MILLED ELEV				888.17	889.36	889.05	889.42	889.79	890.16	889.81	889.46	889.11	889.34	888.17			
MILLED DEPTH (IN)				0.50	0.50	4.29	5.15	4.91	4.45	4.63	4.15	3.35	0.50	0.50			

PAVEMENT DEPTH (IN)				3.66	2.21	6.00	6.00	6.00	6.00	6.00	6.00	6.00	3.15	3.68			
TOP LIFT (IN)				2.00	2.00	2.50	2.50	2.50	2.50	2.50	2.50	2.50	2.00	2.00			
LIFT						2.50	2.50	2.50	2.50	2.50	2.50	2.50					
VARIABLE DEPTH LIFT (IN)				1.66	0.21	1.00	1.00	1.00	1.00	1.00	1.00	1.00	1.15	1.68			

	OFFSET LEFT	110' LEFT (TURF)	SHOULDER EDGE LEFT (TURF)	SHOULDER EDGE LEFT (PAVEMENT)	75' LEFT (SHOULDER)	75' LEFT (RUNWAY)	50' LEFT	25' LEFT	CENTERLINE	25' RIGHT	50' RIGHT	75' RIGHT (RUNWAY)	75' RIGHT (SHOULDER)	SHOULDER EDGE RIGHT (PAVEMENT)	SHOULDER EDGE RIGHT (TURF)	110' RIGHT (TURF)	OFFSET RIGHT
--	-------------	------------------	---------------------------	-------------------------------	---------------------	-------------------	----------	----------	------------	-----------	-----------	--------------------	----------------------	--------------------------------	----------------------------	-------------------	--------------

165+00

MATCH EXISTING	111.10																110.94
EXISTING ELEV		887.96	888.31	888.31	889.44	889.44	889.86	890.20	890.53	890.20	889.82	889.40	889.40	888.25	888.25	887.98	
PROPOSED ELEV		887.88	888.38	888.51	889.56	889.56	889.93	890.30	890.67	890.32	889.97	889.63	889.63	888.50	888.38	887.88	
MILLED ELEV				888.26	889.40	889.06	889.43	889.80	890.17	889.82	889.47	889.13	889.36	888.21			
MILLED DEPTH (IN)				0.50	0.53	4.53	5.11	4.75	4.28	4.47	4.15	3.36	0.50	0.50			
PAVEMENT DEPTH (IN)				2.90	2.00	6.00	6.00	6.00	6.00	6.00	6.00	6.00	3.14	3.52			
TOP LIFT (IN)				2.00	2.00	2.50	2.50	2.50	2.50	2.50	2.50	2.50	2.00	2.00			
LIFT						2.50	2.50	2.50	2.50	2.50	2.50	2.50					
VARIABLE DEPTH LIFT (IN)				0.90	0.00	1.00	1.00	1.00	1.00	1.00	1.00	1.00	1.14	1.52			

	OFFSET LEFT	110' LEFT (TURF)	SHOULDER EDGE LEFT (TURF)	SHOULDER EDGE LEFT (PAVEMENT)	75' LEFT (SHOULDER)	75' LEFT (RUNWAY)	50' LEFT	25' LEFT	CENTERLINE	25' RIGHT	50' RIGHT	75' RIGHT (RUNWAY)	75' RIGHT (SHOULDER)	SHOULDER EDGE RIGHT (PAVEMENT)	SHOULDER EDGE RIGHT (TURF)	110' RIGHT (TURF)	OFFSET RIGHT
--	-------------	------------------	---------------------------	-------------------------------	---------------------	-------------------	----------	----------	------------	-----------	-----------	--------------------	----------------------	--------------------------------	----------------------------	-------------------	--------------

165+25

MATCH EXISTING	111.63																109.96
EXISTING ELEV		887.96	888.29	888.29	889.43	889.43	889.86	890.22	890.53	890.19	889.83	889.42	889.42	888.32	888.32	887.94	
PROPOSED ELEV		887.86	888.36	888.49	889.58	889.58	889.95	890.32	890.69	890.34	889.99	889.64	889.64	888.53	888.40	887.90	
MILLED ELEV				888.25	889.39	889.08	889.45	889.82	890.19	889.84	889.49	889.14	889.38	888.28			
MILLED DEPTH (IN)				0.50	0.50	4.16	4.86	4.72	4.06	4.15	4.09	3.33	0.50	0.50			
PAVEMENT DEPTH (IN)				2.89	2.34	6.00	6.00	6.00	6.00	6.00	6.00	6.00	3.17	2.93			
TOP LIFT (IN)				2.00	2.00	2.50	2.50	2.50	2.50	2.50	2.50	2.50	2.00	2.00			
LIFT						2.50	2.50	2.50	2.50	2.50	2.50	2.50					
VARIABLE DEPTH LIFT (IN)				0.89	0.34	1.00	1.00	1.00	1.00	1.00	1.00	1.00	1.17	0.93			

	OFFSET LEFT	110' LEFT (TURF)	SHOULDER EDGE LEFT (TURF)	SHOULDER EDGE LEFT (PAVEMENT)	75' LEFT (SHOULDER)	75' LEFT (RUNWAY)	50' LEFT	25' LEFT	CENTERLINE	25' RIGHT	50' RIGHT	75' RIGHT (RUNWAY)	75' RIGHT (SHOULDER)	SHOULDER EDGE RIGHT (PAVEMENT)	SHOULDER EDGE RIGHT (TURF)	110' RIGHT (TURF)	OFFSET RIGHT
--	-------------	------------------	---------------------------	-------------------------------	---------------------	-------------------	----------	----------	------------	-----------	-----------	--------------------	----------------------	--------------------------------	----------------------------	-------------------	--------------

165+50

MATCH EXISTING	112.24																111.18
EXISTING ELEV		887.96	888.31	888.31	889.45	889.45	889.87	890.24	890.55	890.20	889.84	889.44	889.44	888.31	888.31	887.95	
PROPOSED ELEV		887.84	888.34	888.47	889.59	889.59	889.96	890.33	890.70	890.34	889.99	889.63	889.63	888.52	888.40	887.90	
MILLED ELEV				888.26	889.41	889.09	889.46	889.83	890.20	889.84	889.49	889.13	889.39	888.27			
MILLED DEPTH (IN)				0.50	0.50	4.32	4.91	4.92	4.15	4.30	4.20	3.65	0.50	0.50			
PAVEMENT DEPTH (IN)				2.44	2.18	6.00	6.00	6.00	6.00	6.00	6.00	6.00	2.85	3.04			
TOP LIFT (IN)				2.00	2.00	2.50	2.50	2.50	2.50	2.50	2.50	2.50	2.00	2.00			
LIFT						2.50	2.50	2.50	2.50	2.50	2.50	2.50					
VARIABLE DEPTH LIFT (IN)				0.44	0.18	1.00	1.00	1.00	1.00	1.00	1.00	1.00	0.85	1.04			

	OFFSET LEFT	110' LEFT (TURF)	SHOULDER EDGE LEFT (TURF)	SHOULDER EDGE LEFT (PAVEMENT)	75' LEFT (SHOULDER)	75' LEFT (RUNWAY)	50' LEFT	25' LEFT	CENTERLINE	25' RIGHT	50' RIGHT	75' RIGHT (RUNWAY)	75' RIGHT (SHOULDER)	SHOULDER EDGE RIGHT (PAVEMENT)	SHOULDER EDGE RIGHT (TURF)	110' RIGHT (TURF)	OFFSET RIGHT
--	-------------	------------------	---------------------------	-------------------------------	---------------------	-------------------	----------	----------	------------	-----------	-----------	--------------------	----------------------	--------------------------------	----------------------------	-------------------	--------------

165+75

MATCH EXISTING	114.19																119.82
EXISTING ELEV		887.99	888.24	888.24	889.44	889.44	889.87	890.25	890.56	890.23	889.84	889.41	889.41	888.31	888.31	888.08	
PROPOSED ELEV		887.81	888.31	888.44	889.56	889.56	889.93	890.30	890.67	890.32	889.96	889.60	889.60	888.52	888.39	887.89	
MILLED ELEV				888.20	889.40	889.06	889.43	889.80	890.17	889.82	889.46	889.10	889.37	888.27			
MILLED DEPTH (IN)				0.50	0.55	4.55	5.27	5.40	4.65	4.91	4.55	3.69	0.50	0.50			
PAVEMENT DEPTH (IN)				2.81	2.00	6.00	6.00	6.00	6.00	6.00	6.00	6.00	2.81	3.01			
TOP LIFT (IN)				2.00	2.00	2.50	2.50	2.50	2.50	2.50	2.50	2.50	2.00	2.00			
LIFT						2.50	2.50	2.50	2.50	2.50	2.50	2.50					
VARIABLE DEPTH LIFT (IN)				0.81	0.00	1.00	1.00	1.00	1.00	1.00	1.00	1.00	0.81	1.01			

	OFFSET LEFT	110' LEFT (TURF)	SHOULDER EDGE LEFT (TURF)	SHOULDER EDGE LEFT (PAVEMENT)	75' LEFT (SHOULDER)	75' LEFT (RUNWAY)	50' LEFT	25' LEFT	CENTERLINE	25' RIGHT	50' RIGHT	75' RIGHT (RUNWAY)	75' RIGHT (SHOULDER)	SHOULDER EDGE RIGHT (PAVEMENT)	SHOULDER EDGE RIGHT (TURF)	110' RIGHT (TURF)	OFFSET RIGHT
166+00																	
MATCH EXISTING	113.50																123.45
EXISTING ELEV		887.91	888.16	888.16	889.43	889.43	889.86	890.22	890.54	890.20	889.84	889.40	889.40	889.58	888.27	888.27	888.08
PROPOSED ELEV		887.77	888.27	888.40	889.54	889.54	889.91	890.27	890.64	890.29	889.93	889.58	889.58	888.51	888.39	887.89	
MILLED ELEV				888.12	889.37	889.04	889.41	889.77	890.14	889.79	889.43	889.08	889.36	888.23			
MILLED DEPTH (IN)				0.50	0.72	4.72	5.41	5.37	4.82	4.99	4.83	3.90	0.50	0.50			
PAVEMENT DEPTH (IN)				3.36	2.00	6.00	6.00	6.00	6.00	6.00	6.00	6.00	2.60	3.37			
TOP LIFT (IN)				2.00	2.00	2.50	2.50	2.50	2.50	2.50	2.50	2.50	2.00	2.00			
LIFT						2.50	2.50	2.50	2.50	2.50	2.50	2.50					
VARIABLE DEPTH LIFT (IN)				1.36	0.00	1.00	1.00	1.00	1.00	1.00	1.00	1.00	0.60	1.37			

	OFFSET LEFT	110' LEFT (TURF)	SHOULDER EDGE LEFT (TURF)	SHOULDER EDGE LEFT (PAVEMENT)	75' LEFT (SHOULDER)	75' LEFT (RUNWAY)	50' LEFT	25' LEFT	CENTERLINE	25' RIGHT	50' RIGHT	75' RIGHT (RUNWAY)	75' RIGHT (SHOULDER)	SHOULDER EDGE RIGHT (PAVEMENT)	SHOULDER EDGE RIGHT (TURF)	110' RIGHT (TURF)	OFFSET RIGHT
166+25																	
MATCH EXISTING	110.83																124.26
EXISTING ELEV		887.80	888.16	888.16	889.39	889.39	889.83	890.19	890.52	890.17	889.81	889.38	889.38	888.26	888.26	888.05	
PROPOSED ELEV		887.73	888.23	888.35	889.51	889.51	889.88	890.25	890.61	890.26	889.90	889.55	889.55	888.46	888.33	887.83	
MILLED ELEV				888.11	889.34	889.01	889.38	889.75	890.11	889.76	889.40	889.05	889.34	888.22			
MILLED DEPTH (IN)				0.50	0.53	4.53	5.46	5.37	4.84	4.93	4.83	3.94	0.50	0.50			
PAVEMENT DEPTH (IN)				2.85	2.00	6.00	6.00	6.00	6.00	6.00	6.00	6.00	2.56	2.82			
TOP LIFT (IN)				2.00	2.00	2.50	2.50	2.50	2.50	2.50	2.50	2.50	2.00	2.00			
LIFT						2.50	2.50	2.50	2.50	2.50	2.50	2.50					
VARIABLE DEPTH LIFT (IN)				0.85	0.00	1.00	1.00	1.00	1.00	1.00	1.00	1.00	0.56	0.82			

	OFFSET LEFT	110' LEFT (TURF)	SHOULDER EDGE LEFT (TURF)	SHOULDER EDGE LEFT (PAVEMENT)	75' LEFT (SHOULDER)	75' LEFT (RUNWAY)	50' LEFT	25' LEFT	CENTERLINE	25' RIGHT	50' RIGHT	75' RIGHT (RUNWAY)	75' RIGHT (SHOULDER)	SHOULDER EDGE RIGHT (PAVEMENT)	SHOULDER EDGE RIGHT (TURF)	110' RIGHT (TURF)	OFFSET RIGHT
166+50																	
MATCH EXISTING	136.26																119.86
EXISTING ELEV		888.10	888.17	888.17	889.38	889.38	889.81	890.17	890.49	890.13	889.76	889.36	889.36	888.21	888.21	887.87	
PROPOSED ELEV		887.69	888.19	888.31	889.48	889.48	889.85	890.22	890.58	890.23	889.88	889.52	889.52	888.38	888.26	887.76	
MILLED ELEV				888.12	889.32	888.98	889.35	889.72	890.08	889.73	889.38	889.02	889.32	888.17			
MILLED DEPTH (IN)				0.50	0.72	4.72	5.55	5.47	4.94	4.82	4.57	4.04	0.50	0.50			
PAVEMENT DEPTH (IN)				2.24	2.00	6.00	6.00	6.00	6.00	6.00	6.00	6.00	2.46	2.57			
TOP LIFT (IN)				2.00	2.00	2.50	2.50	2.50	2.50	2.50	2.50	2.50	2.00	2.00			
LIFT						2.50	2.50	2.50	2.50	2.50	2.50	2.50					
VARIABLE DEPTH LIFT (IN)				0.24	0.00	1.00	1.00	1.00	1.00	1.00	1.00	1.00	0.46	0.57			

	OFFSET LEFT	110' LEFT (TURF)	SHOULDER EDGE LEFT (TURF)	SHOULDER EDGE LEFT (PAVEMENT)	75' LEFT (SHOULDER)	75' LEFT (RUNWAY)	50' LEFT	25' LEFT	CENTERLINE	25' RIGHT	50' RIGHT	75' RIGHT (RUNWAY)	75' RIGHT (SHOULDER)	SHOULDER EDGE RIGHT (PAVEMENT)	SHOULDER EDGE RIGHT (TURF)	110' RIGHT (TURF)	OFFSET RIGHT
166+75																	
MATCH EXISTING	126.22																128.71
EXISTING ELEV		887.89	888.07	888.07	889.33	889.33	889.78	890.15	890.47	890.10	889.71	889.27	889.27	888.11	888.11	887.93	
PROPOSED ELEV		887.65	888.15	888.28	889.46	889.46	889.82	890.19	890.55	890.20	889.85	889.50	889.50	888.31	888.19	887.69	
MILLED ELEV				888.02	889.29	888.96	889.32	889.69	890.05	889.70	889.35	889.00	889.23	888.07			
MILLED DEPTH (IN)				0.50	0.54	4.54	5.46	5.60	5.03	4.79	4.38	3.32	0.50	0.50			
PAVEMENT DEPTH (IN)				3.02	2.00	6.00	6.00	6.00	6.00	6.00	6.00	6.00	3.18	2.93			
TOP LIFT (IN)				2.00	2.00	2.50	2.50	2.50	2.50	2.50	2.50	2.50	2.00	2.00			
LIFT						2.50	2.50	2.50	2.50	2.50	2.50	2.50					
VARIABLE DEPTH LIFT (IN)				1.02	0.00	1.00	1.00	1.00	1.00	1.00	1.00	1.00	1.18	0.93			
167+00																	
MATCH EXISTING	114.64																133.13
EXISTING ELEV		887.81	888.00	888.00	889.25	889.25	889.73	890.12	890.43	890.06	889.69	889.25	889.25	888.06	888.06	887.92	
PROPOSED ELEV		887.62	888.12	888.24	889.43	889.43	889.79	890.16	890.52	890.17	889.82	889.47	889.47	888.24	888.11	887.61	
MILLED ELEV				887.96	889.21	888.93	889.29	889.66	890.02	889.67	889.32	888.97	889.21	888.02			
MILLED DEPTH (IN)				0.50	0.50	3.89	5.20	5.56	4.84	4.67	4.45	3.41	0.50	0.50			
PAVEMENT DEPTH (IN)				3.40	2.61	6.00	6.00	6.00	6.00	6.00	6.00	6.00	3.09	2.61			
TOP LIFT (IN)				2.00	2.00	2.50	2.50	2.50	2.50	2.50	2.50	2.50	2.00	2.00			
LIFT						2.50	2.50	2.50	2.50	2.50	2.50	2.50					
VARIABLE DEPTH LIFT (IN)				1.40	0.61	1.00	1.00	1.00	1.00	1.00	1.00	1.00	1.09	0.61			
167+25																	
MATCH EXISTING	119.69																136.47
EXISTING ELEV		887.77	887.93	887.93	889.21	889.21	889.69	890.09	890.37	890.02	889.65	889.22	889.22	888.00	888.00	887.90	
PROPOSED ELEV		887.58	888.08	888.20	889.40	889.40	889.77	890.13	890.49	890.14	889.79	889.44	889.44	888.17	888.05	887.55	
MILLED ELEV				887.89	889.17	888.90	889.27	889.63	889.99	889.64	889.29	888.94	889.18	887.95			
MILLED DEPTH (IN)				0.50	0.50	3.71	5.03	5.48	4.56	4.52	4.28	3.36	0.50	0.50			
PAVEMENT DEPTH (IN)				3.76	2.79	6.00	6.00	6.00	6.00	6.00	6.00	6.00	3.14	2.65			
TOP LIFT (IN)				2.00	2.00	2.50	2.50	2.50	2.50	2.50	2.50	2.50	2.00	2.00			
LIFT						2.50	2.50	2.50	2.50	2.50	2.50	2.50					
VARIABLE DEPTH LIFT (IN)				1.76	0.79	1.00	1.00	1.00	1.00	1.00	1.00	1.00	1.14	0.65			
167+50																	
MATCH EXISTING	118.88																134.63
EXISTING ELEV		887.80	887.90	887.90	889.18	889.18	889.65	890.04	890.32	889.97	889.59	889.16	889.16	887.96	887.96	887.82	
PROPOSED ELEV		887.52	888.02	888.14	889.34	889.34	889.71	890.07	890.44	890.08	889.72	889.37	889.37	888.15	888.02	887.52	
MILLED ELEV				887.86	889.14	888.84	889.21	889.57	889.94	889.58	889.22	888.87	889.12	887.92			
MILLED DEPTH (IN)				0.50	0.50	4.07	5.29	5.66	4.62	4.66	4.39	3.58	0.50	0.50			

PAVEMENT DEPTH (IN)				3.42	2.43	6.00	6.00	6.00	6.00	6.00	6.00	6.00	2.92	2.74			
TOP LIFT (IN)				2.00	2.00	2.50	2.50	2.50	2.50	2.50	2.50	2.50	2.00	2.00			
LIFT						2.50	2.50	2.50	2.50	2.50	2.50	2.50					
VARIABLE DEPTH LIFT (IN)				1.42	0.43	1.00	1.00	1.00	1.00	1.00	1.00	1.00	0.92	0.74			

	OFFSET LEFT	110' LEFT (TURF)	SHOULDER EDGE LEFT (TURF)	SHOULDER EDGE LEFT (PAVEMENT)	75' LEFT (SHOULDER)	75' LEFT (RUNWAY)	50' LEFT	25' LEFT	CENTERLINE	25' RIGHT	50' RIGHT	75' RIGHT (RUNWAY)	75' RIGHT (SHOULDER)	SHOULDER EDGE RIGHT (PAVEMENT)	SHOULDER EDGE RIGHT (TURF)	110' RIGHT (TURF)	OFFSET RIGHT
--	-------------	------------------	---------------------------	-------------------------------	---------------------	-------------------	----------	----------	------------	-----------	-----------	--------------------	----------------------	--------------------------------	----------------------------	-------------------	--------------

167+75

MATCH EXISTING	114.59																122.00
EXISTING ELEV		887.63	887.81	887.81	889.10	889.10	889.56	889.97	890.27	889.91	889.53	889.09	889.09	887.91	887.91	887.79	
PROPOSED ELEV		887.45	887.95	888.08	889.27	889.27	889.63	890.00	890.36	890.00	889.65	889.29	889.29	888.13	888.01	887.51	
MILLED ELEV				887.76	889.06	888.77	889.13	889.50	889.86	889.50	889.15	888.79	888.05	887.87			
MILLED DEPTH (IN)				0.50	0.50	3.94	5.16	5.64	4.90	4.87	4.53	3.60	0.50	0.50			
PAVEMENT DEPTH (IN)				3.73	2.56	6.00	6.00	6.00	6.00	6.00	6.00	6.00	2.90	3.20			
TOP LIFT (IN)				2.00	2.00	2.50	2.50	2.50	2.50	2.50	2.50	2.50	2.00	2.00			
LIFT						2.50	2.50	2.50	2.50	2.50	2.50	2.50					
VARIABLE DEPTH LIFT (IN)				1.73	0.56	1.00	1.00	1.00	1.00	1.00	1.00	1.00	0.90	1.20			

	OFFSET LEFT	110' LEFT (TURF)	SHOULDER EDGE LEFT (TURF)	SHOULDER EDGE LEFT (PAVEMENT)	75' LEFT (SHOULDER)	75' LEFT (RUNWAY)	50' LEFT	25' LEFT	CENTERLINE	25' RIGHT	50' RIGHT	75' RIGHT (RUNWAY)	75' RIGHT (SHOULDER)	SHOULDER EDGE RIGHT (PAVEMENT)	SHOULDER EDGE RIGHT (TURF)	110' RIGHT (TURF)	OFFSET RIGHT
--	-------------	------------------	---------------------------	-------------------------------	---------------------	-------------------	----------	----------	------------	-----------	-----------	--------------------	----------------------	--------------------------------	----------------------------	-------------------	--------------

168+00

MATCH EXISTING	112.83																122.41
EXISTING ELEV		887.48	887.68	887.68	889.00	889.00	889.48	889.89	890.21	889.85	889.47	889.03	889.03	887.83	887.83	887.82	
PROPOSED ELEV		887.38	887.88	888.00	889.20	889.20	889.56	889.92	890.28	889.93	889.57	889.22	889.22	888.12	888.00	887.50	
MILLED ELEV				887.64	888.96	888.70	889.06	889.42	889.78	889.43	889.07	888.72	888.99	887.78			
MILLED DEPTH (IN)				0.50	0.50	3.65	5.07	5.63	5.07	5.03	4.74	3.74	0.50	0.50			
PAVEMENT DEPTH (IN)				4.42	2.85	6.00	6.00	6.00	6.00	6.00	6.00	6.00	2.76	4.06			
TOP LIFT (IN)				2.00	2.00	2.50	2.50	2.50	2.50	2.50	2.50	2.50	2.00	2.00			
LIFT						2.50	2.50	2.50	2.50	2.50	2.50	2.50					
VARIABLE DEPTH LIFT (IN)				2.42	0.85	1.00	1.00	1.00	1.00	1.00	1.00	1.00	0.76	2.06			

	OFFSET LEFT	110' LEFT (TURF)	SHOULDER EDGE LEFT (TURF)	SHOULDER EDGE LEFT (PAVEMENT)	75' LEFT (SHOULDER)	75' LEFT (RUNWAY)	50' LEFT	25' LEFT	CENTERLINE	25' RIGHT	50' RIGHT	75' RIGHT (RUNWAY)	75' RIGHT (SHOULDER)	SHOULDER EDGE RIGHT (PAVEMENT)	SHOULDER EDGE RIGHT (TURF)	110' RIGHT (TURF)	OFFSET RIGHT
--	-------------	------------------	---------------------------	-------------------------------	---------------------	-------------------	----------	----------	------------	-----------	-----------	--------------------	----------------------	--------------------------------	----------------------------	-------------------	--------------

168+25

MATCH EXISTING	112.75																121.66
EXISTING ELEV		887.39	887.59	887.59	888.93	888.93	889.42	889.81	890.11	889.78	889.41	888.98	888.98	887.70	887.70	887.66	
PROPOSED ELEV		887.31	887.81	887.94	889.12	889.12	889.49	889.85	890.21	889.85	889.50	889.14	889.14	888.12	888.00	887.50	
MILLED ELEV				887.55	888.89	888.62	888.99	889.35	889.71	889.35	889.00	888.64	888.94	887.65			
MILLED DEPTH (IN)				0.50	0.50	3.68	5.16	5.60	4.85	5.07	4.98	4.02	0.50	0.50			
PAVEMENT DEPTH (IN)				4.64	2.82	6.00	6.00	6.00	6.00	6.00	6.00	6.00	2.48	5.61			
TOP LIFT (IN)				2.00	2.00	2.50	2.50	2.50	2.50	2.50	2.50	2.50	2.00	2.00			
LIFT						2.50	2.50	2.50	2.50	2.50	2.50	2.50					
VARIABLE DEPTH LIFT (IN)				2.64	0.82	1.00	1.00	1.00	1.00	1.00	1.00	1.00	0.48	3.61			

	OFFSET LEFT	110' LEFT (TURF)	SHOULDER EDGE LEFT (TURF)	SHOULDER EDGE LEFT (PAVEMENT)	75' LEFT (SHOULDER)	75' LEFT (RUNWAY)	50' LEFT	25' LEFT	CENTERLINE	25' RIGHT	50' RIGHT	75' RIGHT (RUNWAY)	75' RIGHT (SHOULDER)	SHOULDER EDGE RIGHT (PAVEMENT)	SHOULDER EDGE RIGHT (TURF)	110' RIGHT (TURF)	OFFSET RIGHT
--	-------------	------------------	---------------------------	-------------------------------	---------------------	-------------------	----------	----------	------------	-----------	-----------	--------------------	----------------------	--------------------------------	----------------------------	-------------------	--------------

168+50

MATCH EXISTING	117.53																118.32
EXISTING ELEV		887.41	887.57	887.57	888.88	888.88	889.35	889.77	890.05	889.70	889.34	888.92	888.92	887.58	887.58	887.53	
PROPOSED ELEV		887.25	887.75	887.87	889.05	889.05	889.41	889.77	890.13	889.78	889.42	889.07	889.07	888.06	887.94	887.44	
MILLED ELEV				887.53	888.84	888.55	888.91	889.27	889.63	889.28	888.92	888.57	888.88	887.54			
MILLED DEPTH (IN)				0.50	0.50	3.91	5.23	5.97	4.97	5.10	4.98	4.18	0.50	0.50			
PAVEMENT DEPTH (IN)				4.10	2.59	6.00	6.00	6.00	6.00	6.00	6.00	6.00	6.00	2.32	6.27		
TOP LIFT (IN)				2.00	2.00	2.50	2.50	2.50	2.50	2.50	2.50	2.50	2.00	2.00			
LIFT						2.50	2.50	2.50	2.50	2.50	2.50	2.50					
VARIABLE DEPTH LIFT (IN)				2.10	0.59	1.00	1.00	1.00	1.00	1.00	1.00	1.00	0.32	4.27			

	OFFSET LEFT	110' LEFT (TURF)	SHOULDER EDGE LEFT (TURF)	SHOULDER EDGE LEFT (PAVEMENT)	75' LEFT (SHOULDER)	75' LEFT (RUNWAY)	50' LEFT	25' LEFT	CENTERLINE	25' RIGHT	50' RIGHT	75' RIGHT (RUNWAY)	75' RIGHT (SHOULDER)	SHOULDER EDGE RIGHT (PAVEMENT)	SHOULDER EDGE RIGHT (TURF)	110' RIGHT (TURF)	OFFSET RIGHT
168+75																	
MATCH EXISTING	158.02																114.92
EXISTING ELEV		887.41	887.50	887.50	888.79	888.79	889.25	889.63	889.94	889.59	889.24	888.81	888.81	887.54	887.54	887.36	
PROPOSED ELEV		887.18	887.68	887.80	888.98	888.98	889.34	889.70	890.05	889.70	889.35	889.00	889.00	887.92	887.79	887.29	
MILLED ELEV				887.46	888.75	888.48	888.84	889.20	889.55	889.20	888.85	888.50	888.77	887.50			
MILLED DEPTH (IN)				0.50	0.50	3.74	4.90	5.25	4.57	4.71	4.71	3.72	0.50	0.50			
PAVEMENT DEPTH (IN)				4.18	2.76	6.00	6.00	6.00	6.00	6.00	6.00	6.00	2.78	5.04			
TOP LIFT (IN)				2.00	2.00	2.50	2.50	2.50	2.50	2.50	2.50	2.50	2.00	2.00			
LIFT						2.50	2.50	2.50	2.50	2.50	2.50	2.50					
VARIABLE DEPTH LIFT (IN)				2.18	0.76	1.00	1.00	1.00	1.00	1.00	1.00	1.00	0.78	3.04			

	OFFSET LEFT	110' LEFT (TURF)	SHOULDER EDGE LEFT (TURF)	SHOULDER EDGE LEFT (PAVEMENT)	75' LEFT (SHOULDER)	75' LEFT (RUNWAY)	50' LEFT	25' LEFT	CENTERLINE	25' RIGHT	50' RIGHT	75' RIGHT (RUNWAY)	75' RIGHT (SHOULDER)	SHOULDER EDGE RIGHT (PAVEMENT)	SHOULDER EDGE RIGHT (TURF)	110' RIGHT (TURF)	OFFSET RIGHT
169+00																	
MATCH EXISTING	162.04																128.42
EXISTING ELEV		887.39	887.38	887.38	888.69	888.69	889.16	889.57	889.86	889.52	889.16	888.73	888.73	887.45	887.45	887.28	
PROPOSED ELEV		887.12	887.61	887.74	888.91	888.91	889.26	889.62	889.98	889.63	889.28	888.92	888.92	887.80	887.67	887.17	
MILLED ELEV				887.34	888.65	888.41	888.76	889.12	889.48	889.13	888.78	888.42	888.69	887.40			
MILLED DEPTH (IN)				0.50	0.50	3.45	4.82	5.43	4.64	4.74	4.58	3.71	0.50	0.50			
PAVEMENT DEPTH (IN)				4.75	3.05	6.00	6.00	6.00	6.00	6.00	6.00	6.00	2.79	4.74			
TOP LIFT (IN)				2.00	2.00	2.50	2.50	2.50	2.50	2.50	2.50	2.50	2.00	2.00			
LIFT						2.50	2.50	2.50	2.50	2.50	2.50	2.50					
VARIABLE DEPTH LIFT (IN)				2.75	1.05	1.00	1.00	1.00	1.00	1.00	1.00	1.00	0.79	2.74			

	OFFSET LEFT	110' LEFT (TURF)	SHOULDER EDGE LEFT (TURF)	SHOULDER EDGE LEFT (PAVEMENT)	75' LEFT (SHOULDER)	75' LEFT (RUNWAY)	50' LEFT	25' LEFT	CENTERLINE	25' RIGHT	50' RIGHT	75' RIGHT (RUNWAY)	75' RIGHT (SHOULDER)	SHOULDER EDGE RIGHT (PAVEMENT)	SHOULDER EDGE RIGHT (TURF)	110' RIGHT (TURF)	OFFSET RIGHT
169+25																	
MATCH EXISTING	123.27																115.50
EXISTING ELEV		887.26	887.29	887.29	888.62	888.62	889.08	889.48	889.76	889.43	889.07	888.65	888.65	887.35	887.35	887.13	
PROPOSED ELEV		887.04	887.54	887.67	888.83	888.83	889.19	889.54	889.90	889.55	889.19	888.84	888.84	887.68	887.56	887.06	
MILLED ELEV				887.25	888.57	888.33	888.69	889.04	889.40	889.05	888.69	888.34	888.60	887.30			
MILLED DEPTH (IN)				0.50	0.50	3.47	4.68	5.21	4.30	4.60	4.48	3.68	0.50	0.50			
PAVEMENT DEPTH (IN)				4.98	3.03	6.00	6.00	6.00	6.00	6.00	6.00	6.00	2.82	4.57			
TOP LIFT (IN)				2.00	2.00	2.50	2.50	2.50	2.50	2.50	2.50	2.50	2.00	2.00			
LIFT						2.50	2.50	2.50	2.50	2.50	2.50	2.50					
VARIABLE DEPTH LIFT (IN)				2.98	1.03	1.00	1.00	1.00	1.00	1.00	1.00	1.00	0.82	2.57			

	OFFSET LEFT	110' LEFT (TURF)	SHOULDER EDGE LEFT (TURF)	SHOULDER EDGE LEFT (PAVEMENT)	75' LEFT (SHOULDER)	75' LEFT (RUNWAY)	50' LEFT	25' LEFT	CENTERLINE	25' RIGHT	50' RIGHT	75' RIGHT (RUNWAY)	75' RIGHT (SHOULDER)	SHOULDER EDGE RIGHT (PAVEMENT)	SHOULDER EDGE RIGHT (TURF)	110' RIGHT (TURF)	OFFSET RIGHT
169+50																	
MATCH EXISTING	114.86																142.97
EXISTING ELEV		887.04	887.13	887.13	888.51	888.51	888.97	889.37	889.66	889.33	888.97	888.52	888.52	887.25	887.25	887.07	
PROPOSED ELEV		886.95	887.45	887.58	888.73	888.73	889.09	889.45	889.80	889.45	889.10	888.74	888.74	887.57	887.44	886.94	
MILLED ELEV				887.09	888.47	888.23	888.59	888.95	889.30	888.95	888.60	888.24	888.48	887.21			
MILLED DEPTH (IN)				0.50	0.50	3.32	4.57	5.10	4.32	4.58	4.44	3.37	0.50	0.50			
PAVEMENT DEPTH (IN)				5.90	3.18	6.00	6.00	6.00	6.00	6.00	6.00	6.00	3.13	4.29			
TOP LIFT (IN)				2.00	2.00	2.50	2.50	2.50	2.50	2.50	2.50	2.50	2.00	2.00			
LIFT						2.50	2.50	2.50	2.50	2.50	2.50	2.50					
VARIABLE DEPTH LIFT (IN)				3.90	1.18	1.00	1.00	1.00	1.00	1.00	1.00	1.00	1.13	2.29			
169+75																	
MATCH EXISTING	111.94																161.53
EXISTING ELEV		886.95	887.09	887.09	888.40	888.40	888.87	889.27	889.55	889.23	888.88	888.45	888.45	887.16	887.16	886.92	
PROPOSED ELEV		886.86	887.36	887.49	888.64	888.64	888.99	889.35	889.70	889.35	889.00	888.65	888.65	887.46	887.33	886.83	
MILLED ELEV				887.05	888.36	888.14	888.49	888.85	889.20	888.85	888.50	888.15	888.41	887.12			
MILLED DEPTH (IN)				0.50	0.50	3.13	4.49	5.07	4.22	4.51	4.57	3.61	0.50	0.50			
PAVEMENT DEPTH (IN)				5.28	3.37	6.00	6.00	6.00	6.00	6.00	6.00	6.00	2.89	4.09			
TOP LIFT (IN)				2.00	2.00	2.50	2.50	2.50	2.50	2.50	2.50	2.50	2.00	2.00			
LIFT						2.50	2.50	2.50	2.50	2.50	2.50	2.50					
VARIABLE DEPTH LIFT (IN)				3.28	1.37	1.00	1.00	1.00	1.00	1.00	1.00	1.00	0.89	2.09			
170+00																	
MATCH EXISTING	112.67																117.84
EXISTING ELEV		886.91	887.03	887.03	888.32	888.32	888.78	889.20	889.47	889.14	888.79	888.35	888.35	887.07	887.07	886.93	
PROPOSED ELEV		886.78	887.27	887.40	888.54	888.54	888.89	889.25	889.60	889.25	888.90	888.55	888.55	887.34	887.22	886.72	
MILLED ELEV				886.98	888.28	888.04	888.39	888.75	889.10	888.75	888.40	888.05	888.31	887.03			
MILLED DEPTH (IN)				0.50	0.50	3.38	4.59	5.39	4.41	4.60	4.63	3.65	0.50	0.50			
PAVEMENT DEPTH (IN)				4.98	3.12	6.00	6.00	6.00	6.00	6.00	6.00	6.00	2.85	3.81			
TOP LIFT (IN)				2.00	2.00	2.50	2.50	2.50	2.50	2.50	2.50	2.50	2.00	2.00			
LIFT						2.50	2.50	2.50	2.50	2.50	2.50	2.50					
VARIABLE DEPTH LIFT (IN)				2.98	1.12	1.00	1.00	1.00	1.00	1.00	1.00	1.00	0.85	1.81			
170+25																	
MATCH EXISTING	124.58																122.72
EXISTING ELEV		886.58	886.92	886.92	888.22	888.22	888.66	889.06	889.36	889.03	888.69	888.28	888.28	886.96	886.96	886.69	
PROPOSED ELEV		886.69	887.18	887.31	888.44	888.44	888.80	889.15	889.50	889.15	888.80	888.45	888.45	887.23	887.10	886.61	
MILLED ELEV				886.88	888.18	887.94	888.30	888.65	889.00	888.65	888.30	887.95	888.23	886.92			
MILLED DEPTH (IN)				0.50	0.50	3.27	4.37	4.93	4.25	4.49	4.58	3.86	0.50	0.50			

PAVEMENT DEPTH (IN)				5.17	3.23	6.00	6.00	6.00	6.00	6.00	6.00	6.00	2.64	3.73			
TOP LIFT (IN)				2.00	2.00	2.50	2.50	2.50	2.50	2.50	2.50	2.50	2.00	2.00			
LIFT						2.50	2.50	2.50	2.50	2.50	2.50	2.50					
VARIABLE DEPTH LIFT (IN)				3.17	1.23	1.00	1.00	1.00	1.00	1.00	1.00	1.00	0.64	1.73			

	OFFSET LEFT	110' LEFT (TURF)	SHOULDER EDGE LEFT (TURF)	SHOULDER EDGE LEFT (PAVEMENT)	75' LEFT (SHOULDER)	75' LEFT (RUNWAY)	50' LEFT	25' LEFT	CENTERLINE	25' RIGHT	50' RIGHT	75' RIGHT (RUNWAY)	75' RIGHT (SHOULDER)	SHOULDER EDGE RIGHT (PAVEMENT)	SHOULDER EDGE RIGHT (TURF)	110' RIGHT (TURF)	OFFSET RIGHT
--	-------------	------------------	---------------------------	-------------------------------	---------------------	-------------------	----------	----------	------------	-----------	-----------	--------------------	----------------------	--------------------------------	----------------------------	-------------------	--------------

170+50

MATCH EXISTING	126.51																136.96
EXISTING ELEV		886.53	886.85	886.85	888.10	888.10	888.55	888.96	889.26	888.94	888.58	888.13	888.13	886.83	886.83	886.66	
PROPOSED ELEV		886.60	887.10	887.22	888.35	888.35	888.70	889.05	889.40	889.05	888.71	888.36	888.36	887.13	887.00	886.51	
MILLED ELEV				886.81	888.06	887.85	888.20	888.55	888.90	888.55	888.21	887.86	888.09	886.79			
MILLED DEPTH (IN)				0.50	0.50	3.05	4.15	4.88	4.27	4.61	4.49	3.24	0.50	0.50			
PAVEMENT DEPTH (IN)				4.95	3.45	6.00	6.00	6.00	6.00	6.00	6.00	6.00	3.26	4.05			
TOP LIFT (IN)				2.00	2.00	2.50	2.50	2.50	2.50	2.50	2.50	2.50	2.00	2.00			
LIFT						2.50	2.50	2.50	2.50	2.50	2.50	2.50					
VARIABLE DEPTH LIFT (IN)				2.95	1.45	1.00	1.00	1.00	1.00	1.00	1.00	1.00	1.26	2.05			

	OFFSET LEFT	110' LEFT (TURF)	SHOULDER EDGE LEFT (TURF)	SHOULDER EDGE LEFT (PAVEMENT)	75' LEFT (SHOULDER)	75' LEFT (RUNWAY)	50' LEFT	25' LEFT	CENTERLINE	25' RIGHT	50' RIGHT	75' RIGHT (RUNWAY)	75' RIGHT (SHOULDER)	SHOULDER EDGE RIGHT (PAVEMENT)	SHOULDER EDGE RIGHT (TURF)	110' RIGHT (TURF)	OFFSET RIGHT
--	-------------	------------------	---------------------------	-------------------------------	---------------------	-------------------	----------	----------	------------	-----------	-----------	--------------------	----------------------	--------------------------------	----------------------------	-------------------	--------------

170+75

MATCH EXISTING	126.05																132.07
EXISTING ELEV		886.42	886.82	886.82	888.00	888.00	888.44	888.82	889.14	888.86	888.48	888.06	888.06	886.73	886.73	886.54	
PROPOSED ELEV		886.51	887.01	887.13	888.25	888.25	888.60	888.95	889.30	888.96	888.61	888.26	888.26	887.04	886.91	886.41	
MILLED ELEV				886.78	887.95	887.75	888.10	888.45	888.80	888.46	888.11	887.76	888.02	886.69			
MILLED DEPTH (IN)				0.50	0.50	3.00	4.09	4.40	4.07	4.84	4.52	3.56	0.50	0.50			
PAVEMENT DEPTH (IN)				4.22	3.59	6.09	6.00	6.00	6.00	6.00	6.00	6.00	2.94	4.19			
TOP LIFT (IN)				2.00	2.00	2.50	2.50	2.50	2.50	2.50	2.50	2.50	2.00	2.00			
LIFT						2.50	2.50	2.50	2.50	2.50	2.50	2.50					
VARIABLE DEPTH LIFT (IN)				2.22	1.59	1.09	1.00	1.00	1.00	1.00	1.00	1.00	0.94	2.19			

	OFFSET LEFT	110' LEFT (TURF)	SHOULDER EDGE LEFT (TURF)	SHOULDER EDGE LEFT (PAVEMENT)	75' LEFT (SHOULDER)	75' LEFT (RUNWAY)	50' LEFT	25' LEFT	CENTERLINE	25' RIGHT	50' RIGHT	75' RIGHT (RUNWAY)	75' RIGHT (SHOULDER)	SHOULDER EDGE RIGHT (PAVEMENT)	SHOULDER EDGE RIGHT (TURF)	110' RIGHT (TURF)	OFFSET RIGHT
--	-------------	------------------	---------------------------	-------------------------------	---------------------	-------------------	----------	----------	------------	-----------	-----------	--------------------	----------------------	--------------------------------	----------------------------	-------------------	--------------

171+00

MATCH EXISTING	108.92																126.46
EXISTING ELEV		886.45	886.80	886.80	887.93	887.93	888.35	888.74	889.05	888.76	888.38	887.95	887.95	886.66	886.66	886.49	
PROPOSED ELEV		886.41	886.91	887.04	888.16	888.16	888.51	888.85	889.20	888.86	888.51	888.16	888.16	886.95	886.82	886.32	
MILLED ELEV				886.76	887.89	887.66	888.01	888.35	888.70	888.36	888.01	887.66	887.91	886.62			
MILLED DEPTH (IN)				0.50	0.50	3.25	4.12	4.63	4.12	4.79	4.48	3.46	0.50	0.50			
PAVEMENT DEPTH (IN)				3.29	3.25	6.00	6.00	6.00	6.00	6.00	6.00	6.00	3.04	3.92			
TOP LIFT (IN)				2.00	2.00	2.50	2.50	2.50	2.50	2.50	2.50	2.50	2.00	2.00			
LIFT						2.50	2.50	2.50	2.50	2.50	2.50	2.50					
VARIABLE DEPTH LIFT (IN)				1.29	1.25	1.00	1.00	1.00	1.00	1.00	1.00	1.00	1.04	1.92			

	OFFSET LEFT	110' LEFT (TURF)	SHOULDER EDGE LEFT (TURF)	SHOULDER EDGE LEFT (PAVEMENT)	75' LEFT (SHOULDER)	75' LEFT (RUNWAY)	50' LEFT	25' LEFT	CENTERLINE	25' RIGHT	50' RIGHT	75' RIGHT (RUNWAY)	75' RIGHT (SHOULDER)	SHOULDER EDGE RIGHT (PAVEMENT)	SHOULDER EDGE RIGHT (TURF)	110' RIGHT (TURF)	OFFSET RIGHT
--	-------------	------------------	---------------------------	-------------------------------	---------------------	-------------------	----------	----------	------------	-----------	-----------	--------------------	----------------------	--------------------------------	----------------------------	-------------------	--------------

171+25

MATCH EXISTING	127.52																116.27
EXISTING ELEV		886.11	886.61	886.61	887.80	887.80	888.24	888.61	888.95	888.66	888.28	887.84	887.84	886.54	886.54	886.19	
PROPOSED ELEV		886.30	886.80	886.92	888.06	888.06	888.41	888.76	889.10	888.76	888.41	888.07	888.07	886.85	886.73	886.23	
MILLED ELEV				886.57	887.76	887.55	887.91	888.26	888.60	888.26	887.91	887.57	887.80	886.50			
MILLED DEPTH (IN)				0.50	0.50	3.00	3.93	4.28	4.12	4.80	4.39	3.23	0.50	0.50			
PAVEMENT DEPTH (IN)				4.24	3.62	6.12	6.00	6.00	6.00	6.00	6.00	6.00	3.27	4.30			
TOP LIFT (IN)				2.00	2.00	2.50	2.50	2.50	2.50	2.50	2.50	2.50	2.00	2.00			
LIFT						2.50	2.50	2.50	2.50	2.50	2.50	2.50					
VARIABLE DEPTH LIFT (IN)				2.24	1.62	1.12	1.00	1.00	1.00	1.00	1.00	1.00	1.27	2.30			

	OFFSET LEFT	110' LEFT (TURF)	SHOULDER EDGE LEFT (TURF)	SHOULDER EDGE LEFT (PAVEMENT)	75' LEFT (SHOULDER)	75' LEFT (RUNWAY)	50' LEFT	25' LEFT	CENTERLINE	25' RIGHT	50' RIGHT	75' RIGHT (RUNWAY)	75' RIGHT (SHOULDER)	SHOULDER EDGE RIGHT (PAVEMENT)	SHOULDER EDGE RIGHT (TURF)	110' RIGHT (TURF)	OFFSET RIGHT
171+50																	
MATCH EXISTING	126.64																116.61
EXISTING ELEV		886.00	886.53	886.53	887.71	887.71	888.14	888.53	888.87	888.56	888.18	887.76	887.76	886.48	886.48	886.06	
PROPOSED ELEV		886.19	886.69	886.82	887.97	887.97	888.31	888.66	889.00	888.66	888.32	887.97	887.97	886.76	886.64	886.14	
MILLED ELEV				886.49	887.66	887.46	887.81	888.16	888.50	888.16	887.82	887.47	887.72	886.44			
MILLED DEPTH (IN)				0.50	0.50	3.00	3.89	4.43	4.41	4.79	4.37	3.49	0.50	0.50			
PAVEMENT DEPTH (IN)				3.94	3.63	6.13	6.00	6.00	6.00	6.00	6.00	6.00	3.01	3.88			
TOP LIFT (IN)				2.00	2.00	2.50	2.50	2.50	2.50	2.50	2.50	2.50	2.00	2.00			
LIFT						2.50	2.50	2.50	2.50	2.50	2.50	2.50					
VARIABLE DEPTH LIFT (IN)				1.94	1.63	1.13	1.00	1.00	1.00	1.00	1.00	1.00	1.01	1.88			

	OFFSET LEFT	110' LEFT (TURF)	SHOULDER EDGE LEFT (TURF)	SHOULDER EDGE LEFT (PAVEMENT)	75' LEFT (SHOULDER)	75' LEFT (RUNWAY)	50' LEFT	25' LEFT	CENTERLINE	25' RIGHT	50' RIGHT	75' RIGHT (RUNWAY)	75' RIGHT (SHOULDER)	SHOULDER EDGE RIGHT (PAVEMENT)	SHOULDER EDGE RIGHT (TURF)	110' RIGHT (TURF)	OFFSET RIGHT
171+75																	
MATCH EXISTING	122.72																116.53
EXISTING ELEV		886.08	886.43	886.43	887.60	887.60	888.06	888.48	888.79	888.47	888.07	887.63	887.63	886.39	886.39	886.02	
PROPOSED ELEV		886.08	886.58	886.70	887.87	887.87	888.22	888.56	888.90	888.56	888.22	887.87	887.87	886.67	886.55	886.05	
MILLED ELEV				886.39	887.56	887.35	887.72	888.06	888.40	888.06	887.72	887.37	887.59	886.35			
MILLED DEPTH (IN)				0.50	0.50	3.00	4.08	5.10	4.61	4.87	4.29	3.10	0.50	0.50			
PAVEMENT DEPTH (IN)				3.82	3.77	6.27	6.00	6.00	6.00	6.00	6.00	6.00	3.40	3.88			
TOP LIFT (IN)				2.00	2.00	2.50	2.50	2.50	2.50	2.50	2.50	2.50	2.00	2.00			
LIFT						2.50	2.50	2.50	2.50	2.50	2.50	2.50					
VARIABLE DEPTH LIFT (IN)				1.82	1.77	1.27	1.00	1.00	1.00	1.00	1.00	1.00	1.40	1.88			

	OFFSET LEFT	110' LEFT (TURF)	SHOULDER EDGE LEFT (TURF)	SHOULDER EDGE LEFT (PAVEMENT)	75' LEFT (SHOULDER)	75' LEFT (RUNWAY)	50' LEFT	25' LEFT	CENTERLINE	25' RIGHT	50' RIGHT	75' RIGHT (RUNWAY)	75' RIGHT (SHOULDER)	SHOULDER EDGE RIGHT (PAVEMENT)	SHOULDER EDGE RIGHT (TURF)	110' RIGHT (TURF)	OFFSET RIGHT
172+00																	
MATCH EXISTING	113.68																116.75
EXISTING ELEV		886.12	886.38	886.38	887.50	887.50	887.97	888.42	888.69	888.36	887.97	887.54	887.54	886.31	886.31	886.09	
PROPOSED ELEV		885.97	886.47	886.59	887.78	887.78	888.12	888.46	888.80	888.46	888.12	887.78	887.78	886.58	886.45	885.95	
MILLED ELEV				886.34	887.46	887.25	887.62	887.96	888.30	887.96	887.62	887.28	887.50	886.27			
MILLED DEPTH (IN)				0.50	0.50	3.00	4.22	5.48	4.59	4.76	4.23	3.11	0.50	0.50			
PAVEMENT DEPTH (IN)				3.11	3.76	6.26	6.00	6.00	6.00	6.00	6.00	6.00	3.39	3.68			
TOP LIFT (IN)				2.00	2.00	2.50	2.50	2.50	2.50	2.50	2.50	2.50	2.00	2.00			
LIFT						2.50	2.50	2.50	2.50	2.50	2.50	2.50					
VARIABLE DEPTH LIFT (IN)				1.11	1.76	1.26	1.00	1.00	1.00	1.00	1.00	1.00	1.39	1.68			

	OFFSET LEFT	110' LEFT (TURF)	SHOULDER EDGE LEFT (TURF)	SHOULDER EDGE LEFT (PAVEMENT)	75' LEFT (SHOULDER)	75' LEFT (RUNWAY)	50' LEFT	25' LEFT	CENTERLINE	25' RIGHT	50' RIGHT	75' RIGHT (RUNWAY)	75' RIGHT (SHOULDER)	SHOULDER EDGE RIGHT (PAVEMENT)	SHOULDER EDGE RIGHT (TURF)	110' RIGHT (TURF)	OFFSET RIGHT
172+25																	
MATCH EXISTING	112.01																125.14
EXISTING ELEV		886.04	886.23	886.23	887.39	887.39	887.86	888.26	888.58	888.27	887.87	887.42	887.42	886.16	886.16	886.02	
PROPOSED ELEV		885.86	886.36	886.49	887.68	887.68	888.02	888.36	888.70	888.36	888.02	887.68	887.68	886.47	886.34	885.84	
MILLED ELEV				886.19	887.35	887.14	887.52	887.86	888.20	887.86	887.52	887.17	887.38	886.12			
MILLED DEPTH (IN)				0.50	0.50	3.00	4.04	4.79	4.52	4.87	4.17	3.00	0.50	0.50			
PAVEMENT DEPTH (IN)				3.56	3.95	6.45	6.00	6.00	6.00	6.00	6.00	6.17	3.67	4.14			
TOP LIFT (IN)				2.00	2.00	2.50	2.50	2.50	2.50	2.50	2.50	2.50	2.00	2.00			
LIFT						2.50	2.50	2.50	2.50	2.50	2.50	2.50					
VARIABLE DEPTH LIFT (IN)				1.56	1.95	1.45	1.00	1.00	1.00	1.00	1.00	1.17	1.67	2.14			
172+50																	
MATCH EXISTING	119.33																134.90
EXISTING ELEV		886.02	886.08	886.08	887.29	887.29	887.75	888.16	888.46	888.12	887.77	887.32	887.32	886.05	886.05	885.94	
PROPOSED ELEV		885.76	886.26	886.39	887.58	887.58	887.92	888.26	888.60	888.26	887.92	887.59	887.59	886.34	886.22	885.72	
MILLED ELEV				886.04	887.25	887.04	887.42	887.76	888.10	887.76	887.42	887.07	887.28	886.01			
MILLED DEPTH (IN)				0.50	0.50	3.00	3.92	4.74	4.29	4.29	4.09	3.00	0.50	0.50			
PAVEMENT DEPTH (IN)				4.16	4.01	6.51	6.00	6.00	6.00	6.00	6.00	6.18	3.68	4.00			
TOP LIFT (IN)				2.00	2.00	2.50	2.50	2.50	2.50	2.50	2.50	2.50	2.00	2.00			
LIFT						2.50	2.50	2.50	2.50	2.50	2.50	2.50					
VARIABLE DEPTH LIFT (IN)				2.16	2.01	1.51	1.00	1.00	1.00	1.00	1.00	1.18	1.68	2.00			
172+75																	
MATCH EXISTING	115.18																111.12
EXISTING ELEV		885.88	885.92	885.92	887.17	887.17	887.64	888.02	888.35	888.01	887.66	887.22	887.22	885.88	885.88	885.61	
PROPOSED ELEV		885.66	886.16	886.29	887.49	887.49	887.83	888.17	888.50	888.16	887.83	887.49	887.49	886.22	886.09	885.60	
MILLED ELEV				885.87	887.13	886.92	887.33	887.67	888.00	887.66	887.33	886.97	887.18	885.84			
MILLED DEPTH (IN)				0.50	0.50	3.00	3.79	4.24	4.20	4.15	3.97	3.00	0.50	0.50			
PAVEMENT DEPTH (IN)				4.98	4.27	6.77	6.00	6.00	6.00	6.00	6.00	6.24	3.74	4.52			
TOP LIFT (IN)				2.00	2.00	2.50	2.50	2.50	2.50	2.50	2.50	2.50	2.00	2.00			
LIFT						2.50	2.50	2.50	2.50	2.50	2.50	2.50					
VARIABLE DEPTH LIFT (IN)				2.98	2.27	1.77	1.00	1.00	1.00	1.00	1.00	1.24	1.74	2.52			
173+00																	
MATCH EXISTING	113.33																112.88
EXISTING ELEV		885.73	885.88	885.88	887.09	887.09	887.55	887.94	888.26	887.93	887.56	887.14	887.14	885.79	885.79	885.58	
PROPOSED ELEV		885.56	886.06	886.19	887.39	887.39	887.73	888.07	888.40	888.07	887.73	887.39	887.39	886.10	885.97	885.47	
MILLED ELEV				885.84	887.05	886.84	887.23	887.57	887.90	887.57	887.23	886.89	887.10	885.74			
MILLED DEPTH (IN)				0.50	0.50	3.00	3.82	4.44	4.27	4.39	3.99	3.00	0.50	0.50			

PAVEMENT DEPTH (IN)				4.23	4.09	6.59	6.00	6.00	6.00	6.00	6.00	6.04	3.54	4.22			
TOP LIFT (IN)				2.00	2.00	2.50	2.50	2.50	2.50	2.50	2.50	2.50	2.00	2.00			
LIFT						2.50	2.50	2.50	2.50	2.50	2.50	2.50					
VARIABLE DEPTH LIFT (IN)				2.23	2.09	1.59	1.00	1.00	1.00	1.00	1.00	1.04	1.54	2.22			
	OFFSET LEFT	110' LEFT (TURF)	SHOULDER EDGE LEFT (TURF)	SHOULDER EDGE LEFT (PAVEMENT)	75' LEFT (SHOULDER)	75' LEFT (RUNWAY)	50' LEFT	25' LEFT	CENTERLINE	25' RIGHT	50' RIGHT	75' RIGHT (RUNWAY)	75' RIGHT (SHOULDER)	SHOULDER EDGE RIGHT (PAVEMENT)	SHOULDER EDGE RIGHT (TURF)	110' RIGHT (TURF)	OFFSET RIGHT
173+25																	
MATCH EXISTING	115.51																124.86
EXISTING ELEV		885.64	885.74	885.74	886.99	886.99	887.45	887.82	888.14	887.84	887.47	887.04	887.04	885.73	885.73	885.20	
PROPOSED ELEV		885.47	885.96	886.09	887.30	887.30	887.63	887.97	888.30	887.97	887.63	887.30	887.30	885.97	885.85	885.35	
MILLED ELEV				885.69	886.95	886.74	887.13	887.47	887.80	887.47	887.13	886.79	887.00	885.69			
MILLED DEPTH (IN)				0.50	0.50	3.00	3.83	4.27	4.08	4.47	4.01	3.00	0.50	0.50			
PAVEMENT DEPTH (IN)				4.74	4.16	6.66	6.00	6.00	6.00	6.00	6.00	6.07	3.57	3.37			
TOP LIFT (IN)				2.00	2.00	2.50	2.50	2.50	2.50	2.50	2.50	2.50	2.00	2.00			
LIFT						2.50	2.50	2.50	2.50	2.50	2.50	2.50					
VARIABLE DEPTH LIFT (IN)				2.74	2.16	1.66	1.00	1.00	1.00	1.00	1.00	1.07	1.57	1.37			
	OFFSET LEFT	110' LEFT (TURF)	SHOULDER EDGE LEFT (TURF)	SHOULDER EDGE LEFT (PAVEMENT)	75' LEFT (SHOULDER)	75' LEFT (RUNWAY)	50' LEFT	25' LEFT	CENTERLINE	25' RIGHT	50' RIGHT	75' RIGHT (RUNWAY)	75' RIGHT (SHOULDER)	SHOULDER EDGE RIGHT (PAVEMENT)	SHOULDER EDGE RIGHT (TURF)	110' RIGHT (TURF)	OFFSET RIGHT
173+50																	
MATCH EXISTING	116.82																114.79
EXISTING ELEV		885.50	885.63	885.63	886.90	886.90	887.36	887.72	888.05	887.72	887.36	886.95	886.95	885.63	885.63	885.32	
PROPOSED ELEV		885.37	885.86	885.99	887.20	887.20	887.54	887.87	888.20	887.87	887.53	887.20	887.20	885.85	885.73	885.23	
MILLED ELEV				885.58	886.86	886.65	887.04	887.37	887.70	887.37	887.03	886.70	886.91	885.59			
MILLED DEPTH (IN)				0.50	0.50	3.00	3.84	4.21	4.19	4.20	3.92	3.00	0.50	0.50			
PAVEMENT DEPTH (IN)				4.86	4.13	6.63	6.00	6.00	6.00	6.00	6.00	6.00	3.50	3.13			
TOP LIFT (IN)				2.00	2.00	2.50	2.50	2.50	2.50	2.50	2.50	2.50	2.00	2.00			
LIFT						2.50	2.50	2.50	2.50	2.50	2.50	2.50					
VARIABLE DEPTH LIFT (IN)				2.86	2.13	1.63	1.00	1.00	1.00	1.00	1.00	1.00	1.50	1.13			
	OFFSET LEFT	110' LEFT (TURF)	SHOULDER EDGE LEFT (TURF)	SHOULDER EDGE LEFT (PAVEMENT)	75' LEFT (SHOULDER)	75' LEFT (RUNWAY)	50' LEFT	25' LEFT	CENTERLINE	25' RIGHT	50' RIGHT	75' RIGHT (RUNWAY)	75' RIGHT (SHOULDER)	SHOULDER EDGE RIGHT (PAVEMENT)	SHOULDER EDGE RIGHT (TURF)	110' RIGHT (TURF)	OFFSET RIGHT
173+75																	
MATCH EXISTING	130.21																113.17
EXISTING ELEV		885.41	885.51	885.51	886.82	886.82	887.26	887.62	887.95	887.60	887.25	886.82	886.82	885.53	885.53	885.17	
PROPOSED ELEV		885.27	885.77	885.89	887.11	887.11	887.44	887.77	888.10	887.77	887.44	887.10	887.10	885.73	885.60	885.10	
MILLED ELEV				885.47	886.77	886.57	886.94	887.27	887.60	887.27	886.94	886.57	886.78	885.49			
MILLED DEPTH (IN)				0.50	0.50	3.00	3.88	4.19	4.14	4.00	3.75	3.00	0.50	0.50			
PAVEMENT DEPTH (IN)				5.08	3.98	6.48	6.00	6.00	6.00	6.00	6.00	6.37	3.87	2.86			
TOP LIFT (IN)				2.00	2.00	2.50	2.50	2.50	2.50	2.50	2.50	2.50	2.00	2.00			
LIFT						2.50	2.50	2.50	2.50	2.50	2.50	2.50					
VARIABLE DEPTH LIFT (IN)				3.08	1.98	1.48	1.00	1.00	1.00	1.00	1.00	1.37	1.87	0.86			
	OFFSET LEFT	110' LEFT (TURF)	SHOULDER EDGE LEFT (TURF)	SHOULDER EDGE LEFT (PAVEMENT)	75' LEFT (SHOULDER)	75' LEFT (RUNWAY)	50' LEFT	25' LEFT	CENTERLINE	25' RIGHT	50' RIGHT	75' RIGHT (RUNWAY)	75' RIGHT (SHOULDER)	SHOULDER EDGE RIGHT (PAVEMENT)	SHOULDER EDGE RIGHT (TURF)	110' RIGHT (TURF)	OFFSET RIGHT
174+00																	

MATCH EXISTING	148.68																117.66
EXISTING ELEV		885.35	885.44	885.44	886.72	886.72	887.21	887.55	887.86	887.52	887.16	886.73	886.73	885.40	885.40	885.21	
PROPOSED ELEV		885.18	885.67	885.80	887.01	887.01	887.34	887.67	888.00	887.67	887.34	887.01	887.01	885.61	885.48	884.98	
MILLED ELEV				885.40	886.68	886.47	886.84	887.17	887.50	887.17	886.84	886.48	886.69	885.36			
MILLED DEPTH (IN)				0.50	0.50	3.00	4.45	4.51	4.34	4.16	3.86	3.00	0.50	0.50			
PAVEMENT DEPTH (IN)				4.85	3.99	6.49	6.00	6.00	6.00	6.00	6.00	6.32	3.82	2.97			
TOP LIFT (IN)				2.00	2.00	2.50	2.50	2.50	2.50	2.50	2.50	2.50	2.00	2.00			
LIFT						2.50	2.50	2.50	2.50	2.50	2.50	2.50					
VARIABLE DEPTH LIFT (IN)				2.85	1.99	1.49	1.00	1.00	1.00	1.00	1.00	1.32	1.82	0.97			

	OFFSET LEFT	110' LEFT (TURF)	SHOULDER EDGE LEFT (TURF)	SHOULDER EDGE LEFT (PAVEMENT)	75' LEFT (SHOULDER)	75' LEFT (RUNWAY)	50' LEFT	25' LEFT	CENTERLINE	25' RIGHT	50' RIGHT	75' RIGHT (RUNWAY)	75' RIGHT (SHOULDER)	SHOULDER EDGE RIGHT (PAVEMENT)	SHOULDER EDGE RIGHT (TURF)	110' RIGHT (TURF)	OFFSET RIGHT
174+25																	
MATCH EXISTING	142.57																119.48
EXISTING ELEV		885.25	885.33	885.33	886.59	886.59	887.04	887.42	887.76	887.42	887.07	886.64	886.64	885.32	885.32	884.91	
PROPOSED ELEV		885.08	885.58	885.71	886.91	886.91	887.24	887.57	887.90	887.57	887.24	886.91	886.91	885.53	885.41	884.91	
MILLED ELEV				885.29	886.55	886.34	886.74	887.07	887.40	887.07	886.74	886.39	886.60	885.28			
MILLED DEPTH (IN)				0.50	0.50	3.00	3.50	4.11	4.27	4.20	3.93	3.00	0.50	0.50			
PAVEMENT DEPTH (IN)				4.96	4.38	6.88	6.00	6.00	6.00	6.00	6.00	6.27	3.77	3.02			
TOP LIFT (IN)				2.00	2.00	2.50	2.50	2.50	2.50	2.50	2.50	2.50	2.00	2.00			
LIFT						2.50	2.50	2.50	2.50	2.50	2.50	2.50					
VARIABLE DEPTH LIFT (IN)				2.96	2.38	1.88	1.00	1.00	1.00	1.00	1.00	1.27	1.77	1.02			

	OFFSET LEFT	110' LEFT (TURF)	SHOULDER EDGE LEFT (TURF)	SHOULDER EDGE LEFT (PAVEMENT)	75' LEFT (SHOULDER)	75' LEFT (RUNWAY)	50' LEFT	25' LEFT	CENTERLINE	25' RIGHT	50' RIGHT	75' RIGHT (RUNWAY)	75' RIGHT (SHOULDER)	SHOULDER EDGE RIGHT (PAVEMENT)	SHOULDER EDGE RIGHT (TURF)	110' RIGHT (TURF)	OFFSET RIGHT
174+50																	
MATCH EXISTING	140.14																122.44
EXISTING ELEV		885.15	885.26	885.26	886.46	886.46	886.92	887.32	887.68	887.35	886.97	886.55	886.55	885.24	885.24	884.81	
PROPOSED ELEV		884.99	885.48	885.61	886.82	886.82	887.15	887.48	887.80	887.47	887.14	886.81	886.81	885.47	885.34	884.84	
MILLED ELEV				885.21	886.41	886.21	886.65	886.98	887.30	886.97	886.64	886.30	886.51	885.20			
MILLED DEPTH (IN)				0.50	0.50	3.00	3.22	4.10	4.47	4.57	3.93	3.00	0.50	0.50			
PAVEMENT DEPTH (IN)				4.74	4.84	7.34	6.00	6.00	6.00	6.00	6.00	6.19	3.69	3.20			
TOP LIFT (IN)				2.00	2.00	2.50	2.50	2.50	2.50	2.50	2.50	2.50	2.00	2.00			
LIFT						2.50	2.50	2.50	2.50	2.50	2.50	2.50					
VARIABLE DEPTH LIFT (IN)				2.74	2.84	2.34	1.00	1.00	1.00	1.00	1.00	1.19	1.69	1.20			

	OFFSET LEFT	110' LEFT (TURF)	SHOULDER EDGE LEFT (TURF)	SHOULDER EDGE LEFT (PAVEMENT)	75' LEFT (SHOULDER)	75' LEFT (RUNWAY)	50' LEFT	25' LEFT	CENTERLINE	25' RIGHT	50' RIGHT	75' RIGHT (RUNWAY)	75' RIGHT (SHOULDER)	SHOULDER EDGE RIGHT (PAVEMENT)	SHOULDER EDGE RIGHT (TURF)	110' RIGHT (TURF)	OFFSET RIGHT
174+75																	
MATCH EXISTING	130.18																113.04
EXISTING ELEV		885.06	885.20	885.20	886.37	886.37	886.85	887.26	887.58	887.24	886.87	886.43	886.43	885.16	885.16	884.84	
PROPOSED ELEV		884.89	885.39	885.52	886.72	886.72	887.05	887.38	887.70	887.37	887.04	886.72	886.72	885.40	885.27	884.77	
MILLED ELEV				885.15	886.33	886.12	886.55	886.88	887.20	886.87	886.54	886.18	886.38	885.11			
MILLED DEPTH (IN)				0.50	0.50	3.00	3.60	4.57	4.47	4.42	3.84	3.00	0.50	0.50			
PAVEMENT DEPTH (IN)				4.35	4.70	7.20	6.00	6.00	6.00	6.00	6.00	6.48	3.98	3.42			
TOP LIFT (IN)				2.00	2.00	2.50	2.50	2.50	2.50	2.50	2.50	2.50	2.00	2.00			
LIFT						2.50	2.50	2.50	2.50	2.50	2.50	2.50					
VARIABLE DEPTH LIFT (IN)				2.35	2.70	2.20	1.00	1.00	1.00	1.00	1.00	1.48	1.98	1.42			

	OFFSET LEFT	110' LEFT (TURF)	SHOULDER EDGE LEFT (TURF)	SHOULDER EDGE LEFT (PAVEMENT)	75' LEFT (SHOULDER)	75' LEFT (RUNWAY)	50' LEFT	25' LEFT	CENTERLINE	25' RIGHT	50' RIGHT	75' RIGHT (RUNWAY)	75' RIGHT (SHOULDER)	SHOULDER EDGE RIGHT (PAVEMENT)	SHOULDER EDGE RIGHT (TURF)	110' RIGHT (TURF)	OFFSET RIGHT
175+00																	
MATCH EXISTING	115.11																116.39
EXISTING ELEV		885.02	885.08	885.08	886.32	886.32	886.79	887.14	887.46	887.12	886.77	886.32	886.32	885.10	885.10	884.99	
PROPOSED ELEV		884.80	885.30	885.42	886.63	886.63	886.95	887.28	887.60	887.27	886.95	886.62	886.62	885.33	885.20	884.71	
MILLED ELEV				885.03	886.28	886.07	886.45	886.78	887.10	886.77	886.45	886.07	886.28	885.06			
MILLED DEPTH (IN)				0.50	0.50	3.00	4.06	4.34	4.29	4.19	3.82	3.00	0.50	0.50			
PAVEMENT DEPTH (IN)				4.65	4.21	6.71	6.00	6.00	6.00	6.00	6.00	6.55	4.05	3.27			
TOP LIFT (IN)				2.00	2.00	2.50	2.50	2.50	2.50	2.50	2.50	2.50	2.00	2.00			
LIFT						2.50	2.50	2.50	2.50	2.50	2.50	2.50					
VARIABLE DEPTH LIFT (IN)				2.65	2.21	1.71	1.00	1.00	1.00	1.00	1.00	1.55	2.05	1.27			
175+25																	
MATCH EXISTING	115.99																115.18
EXISTING ELEV		884.85	884.96	884.96	886.21	886.21	886.64	887.02	887.35	887.02	886.67	886.22	886.22	885.06	885.06	884.76	
PROPOSED ELEV		884.71	885.21	885.33	886.53	886.53	886.86	887.18	887.50	887.18	886.85	886.53	886.53	885.26	885.14	884.64	
MILLED ELEV				884.92	886.17	885.96	886.36	886.68	887.00	886.68	886.35	885.97	886.18	885.02			
MILLED DEPTH (IN)				0.50	0.50	3.00	3.46	4.11	4.21	4.08	3.84	3.00	0.50	0.50			
PAVEMENT DEPTH (IN)				4.89	4.37	6.87	6.00	6.00	6.00	6.00	6.00	6.68	4.18	2.95			
TOP LIFT (IN)				2.00	2.00	2.50	2.50	2.50	2.50	2.50	2.50	2.50	2.00	2.00			
LIFT						2.50	2.50	2.50	2.50	2.50	2.50	2.50					
VARIABLE DEPTH LIFT (IN)				2.89	2.37	1.87	1.00	1.00	1.00	1.00	1.00	1.68	2.18	0.95			
175+50																	
MATCH EXISTING	113.39																120.68
EXISTING ELEV		884.76	884.85	884.85	886.09	886.09	886.53	886.92	887.26	886.93	886.59	886.15	886.15	884.97	884.97	884.78	
PROPOSED ELEV		884.61	885.12	885.24	886.45	886.45	886.77	887.09	887.40	887.08	886.77	886.46	886.46	885.18	885.06	884.56	
MILLED ELEV				884.81	886.05	885.84	886.27	886.59	886.90	886.58	886.27	885.90	886.11	884.93			
MILLED DEPTH (IN)				0.50	0.50	3.00	3.15	4.00	4.32	4.13	3.87	3.00	0.50	0.50			
PAVEMENT DEPTH (IN)				5.15	4.81	7.31	6.00	6.00	6.00	6.00	6.00	6.63	4.13	3.07			
TOP LIFT (IN)				2.00	2.00	2.50	2.50	2.50	2.50	2.50	2.50	2.50	2.00	2.00			
LIFT						2.50	2.50	2.50	2.50	2.50	2.50	2.50					
VARIABLE DEPTH LIFT (IN)				3.15	2.81	2.31	1.00	1.00	1.00	1.00	1.00	1.63	2.13	1.07			
175+75																	
MATCH EXISTING	112.63																127.17
EXISTING ELEV		884.67	884.77	884.77	886.01	886.01	886.45	886.81	887.15	886.84	886.51	886.08	886.08	884.81	884.81	884.78	
PROPOSED ELEV		884.52	885.02	885.15	886.38	886.38	886.69	887.00	887.31	887.00	886.69	886.38	886.38	885.10	884.97	884.47	
MILLED ELEV				884.73	885.97	885.76	886.19	886.50	886.81	886.50	886.19	885.83	886.03	884.77			
MILLED DEPTH (IN)				0.50	0.50	3.00	3.12	3.68	4.07	4.00	3.79	3.00	0.50	0.50			

PAVEMENT DEPTH (IN)				5.02	4.91	7.41	6.00	6.00	6.00	6.00	6.00	6.68	4.18	3.90			
TOP LIFT (IN)				2.00	2.00	2.50	2.50	2.50	2.50	2.50	2.50	2.50	2.00	2.00			
LIFT						2.50	2.50	2.50	2.50	2.50	2.50	2.50					
VARIABLE DEPTH LIFT (IN)				3.02	2.91	2.41	1.00	1.00	1.00	1.00	1.00	1.68	2.18	1.90			
	OFFSET LEFT	110' LEFT (TURF)	SHOULDER EDGE LEFT (TURF)	SHOULDER EDGE LEFT (PAVEMENT)	75' LEFT (SHOULDER)	75' LEFT (RUNWAY)	50' LEFT	25' LEFT	CENTERLINE	25' RIGHT	50' RIGHT	75' RIGHT (RUNWAY)	75' RIGHT (SHOULDER)	SHOULDER EDGE RIGHT (PAVEMENT)	SHOULDER EDGE RIGHT (TURF)	110' RIGHT (TURF)	OFFSET RIGHT
176+00																	
MATCH EXISTING	112.40																131.37
EXISTING ELEV		884.55	884.69	884.69	885.94	885.94	886.37	886.72	887.07	886.75	886.43	886.01	886.01	884.83	884.83	884.85	
PROPOSED ELEV		884.43	884.93	885.06	886.30	886.30	886.62	886.93	887.24	886.93	886.62	886.31	886.31	885.00	884.88	884.38	
MILLED ELEV				884.65	885.90	885.69	886.12	886.43	886.74	886.43	886.12	885.76	885.97	884.79			
MILLED DEPTH (IN)				0.50	0.50	3.00	3.04	3.56	3.95	3.84	3.69	3.00	0.50	0.50			
PAVEMENT DEPTH (IN)				4.94	4.83	7.33	6.00	6.00	6.00	6.00	6.00	6.54	4.04	2.60			
TOP LIFT (IN)				2.00	2.00	2.50	2.50	2.50	2.50	2.50	2.50	2.50	2.00	2.00			
LIFT						2.50	2.50	2.50	2.50	2.50	2.50	2.50					
VARIABLE DEPTH LIFT (IN)				2.94	2.83	2.33	1.00	1.00	1.00	1.00	1.00	1.54	2.04	0.60			
	OFFSET LEFT	110' LEFT (TURF)	SHOULDER EDGE LEFT (TURF)	SHOULDER EDGE LEFT (PAVEMENT)	75' LEFT (SHOULDER)	75' LEFT (RUNWAY)	50' LEFT	25' LEFT	CENTERLINE	25' RIGHT	50' RIGHT	75' RIGHT (RUNWAY)	75' RIGHT (SHOULDER)	SHOULDER EDGE RIGHT (PAVEMENT)	SHOULDER EDGE RIGHT (TURF)	110' RIGHT (TURF)	OFFSET RIGHT
176+25																	
MATCH EXISTING	110.21																123.18
EXISTING ELEV		884.40	884.63	884.63	885.83	885.83	886.28	886.64	886.98	886.66	886.34	885.94	885.94	884.82	884.82	884.52	
PROPOSED ELEV		884.34	884.84	884.97	886.23	886.23	886.54	886.85	887.16	886.85	886.55	886.24	886.24	884.95	884.83	884.33	
MILLED ELEV				884.59	885.79	885.58	886.03	886.35	886.66	886.35	886.05	885.69	885.90	884.78			
MILLED DEPTH (IN)				0.50	0.50	3.00	3.00	3.47	3.86	3.68	3.53	3.00	0.50	0.50			
PAVEMENT DEPTH (IN)				4.51	5.32	7.82	6.11	6.00	6.00	6.00	6.00	6.51	4.01	2.11			
TOP LIFT (IN)				2.00	2.00	2.50	2.50	2.50	2.50	2.50	2.50	2.50	2.00	2.00			
LIFT						2.50	2.50	2.50	2.50	2.50	2.50	2.50					
VARIABLE DEPTH LIFT (IN)				2.51	3.32	2.82	1.11	1.00	1.00	1.00	1.00	1.51	2.01	0.11			
	OFFSET LEFT	110' LEFT (TURF)	SHOULDER EDGE LEFT (TURF)	SHOULDER EDGE LEFT (PAVEMENT)	75' LEFT (SHOULDER)	75' LEFT (RUNWAY)	50' LEFT	25' LEFT	CENTERLINE	25' RIGHT	50' RIGHT	75' RIGHT (RUNWAY)	75' RIGHT (SHOULDER)	SHOULDER EDGE RIGHT (PAVEMENT)	SHOULDER EDGE RIGHT (TURF)	110' RIGHT (TURF)	OFFSET RIGHT
176+50																	
MATCH EXISTING	109.61																126.13
EXISTING ELEV		884.30	884.60	884.60	885.76	885.76	886.20	886.56	886.91	886.58	886.26	885.88	885.88	884.75	884.75	884.43	
PROPOSED ELEV		884.25	884.75	884.88	886.16	886.16	886.47	886.78	887.09	886.78	886.47	886.16	886.16	884.93	884.80	884.30	
MILLED ELEV				884.56	885.72	885.51	885.95	886.28	886.59	886.28	885.97	885.63	885.84	884.71			
MILLED DEPTH (IN)				0.50	0.50	3.00	3.00	3.42	3.90	3.65	3.49	3.00	0.50	0.50			
PAVEMENT DEPTH (IN)				3.83	5.29	7.79	6.23	6.00	6.00	6.00	6.00	6.43	3.93	2.58			
TOP LIFT (IN)				2.00	2.00	2.50	2.50	2.50	2.50	2.50	2.50	2.50	2.00	2.00			
LIFT						2.50	2.50	2.50	2.50	2.50	2.50	2.50					
VARIABLE DEPTH LIFT (IN)				1.83	3.29	2.79	1.23	1.00	1.00	1.00	1.00	1.43	1.93	0.58			
	OFFSET LEFT	110' LEFT (TURF)	SHOULDER EDGE LEFT (TURF)	SHOULDER EDGE LEFT (PAVEMENT)	75' LEFT (SHOULDER)	75' LEFT (RUNWAY)	50' LEFT	25' LEFT	CENTERLINE	25' RIGHT	50' RIGHT	75' RIGHT (RUNWAY)	75' RIGHT (SHOULDER)	SHOULDER EDGE RIGHT (PAVEMENT)	SHOULDER EDGE RIGHT (TURF)	110' RIGHT (TURF)	OFFSET RIGHT
176+75																	

MATCH EXISTING	110.82																133.39
EXISTING ELEV		884.27	884.52	884.52	885.67	885.67	886.12	886.49	886.83	886.51	886.18	885.79	885.79	884.68	884.68	884.42	
PROPOSED ELEV		884.17	884.67	884.79	886.09	886.09	886.39	886.70	887.01	886.70	886.40	886.09	886.09	884.89	884.76	884.26	
MILLED ELEV				884.48	885.63	885.42	885.87	886.20	886.51	886.20	885.90	885.54	885.74	884.64			
MILLED DEPTH (IN)				0.50	0.50	3.00	3.00	3.41	3.83	3.68	3.41	3.00	0.50	0.50			
PAVEMENT DEPTH (IN)				3.78	5.53	8.03	6.26	6.00	6.00	6.00	6.00	6.66	4.16	2.98			
TOP LIFT (IN)				2.00	2.00	2.50	2.50	2.50	2.50	2.50	2.50	2.50	2.00	2.00			
LIFT						2.50	2.50	2.50	2.50	2.50	2.50	2.50					
VARIABLE DEPTH LIFT (IN)				1.78	3.53	3.03	1.26	1.00	1.00	1.00	1.00	1.66	2.16	0.98			

	OFFSET LEFT	110' LEFT (TURF)	SHOULDER EDGE LEFT (TURF)	SHOULDER EDGE LEFT (PAVEMENT)	75' LEFT (SHOULDER)	75' LEFT (RUNWAY)	50' LEFT	25' LEFT	CENTERLINE	25' RIGHT	50' RIGHT	75' RIGHT (RUNWAY)	75' RIGHT (SHOULDER)	SHOULDER EDGE RIGHT (PAVEMENT)	SHOULDER EDGE RIGHT (TURF)	110' RIGHT (TURF)	OFFSET RIGHT
177+00																	
MATCH EXISTING	110.25																135.44
EXISTING ELEV		884.17	884.45	884.45	885.64	885.64	886.08	886.43	886.76	886.45	886.12	885.71	885.71	884.58	884.58	884.59	
PROPOSED ELEV		884.11	884.61	884.73	886.01	886.01	886.32	886.63	886.94	886.63	886.32	886.02	886.02	884.81	884.69	884.19	
MILLED ELEV				884.40	885.60	885.39	885.82	886.13	886.44	886.13	885.82	885.46	885.66	884.54			
MILLED DEPTH (IN)				0.50	0.50	3.00	3.10	3.66	3.93	3.81	3.52	3.00	0.50	0.50			
PAVEMENT DEPTH (IN)				3.91	4.95	7.45	6.00	6.00	6.00	6.00	6.00	6.75	4.25	3.27			
TOP LIFT (IN)				2.00	2.00	2.50	2.50	2.50	2.50	2.50	2.50	2.50	2.00	2.00			
LIFT						2.50	2.50	2.50	2.50	2.50	2.50	2.50					
VARIABLE DEPTH LIFT (IN)				1.91	2.95	2.45	1.00	1.00	1.00	1.00	1.00	1.75	2.25	1.27			

	OFFSET LEFT	110' LEFT (TURF)	SHOULDER EDGE LEFT (TURF)	SHOULDER EDGE LEFT (PAVEMENT)	75' LEFT (SHOULDER)	75' LEFT (RUNWAY)	50' LEFT	25' LEFT	CENTERLINE	25' RIGHT	50' RIGHT	75' RIGHT (RUNWAY)	75' RIGHT (SHOULDER)	SHOULDER EDGE RIGHT (PAVEMENT)	SHOULDER EDGE RIGHT (TURF)	110' RIGHT (TURF)	OFFSET RIGHT
177+25																	
MATCH EXISTING	109.60																138.49
EXISTING ELEV		884.11	884.44	884.44	885.60	885.60	886.03	886.37	886.70	886.39	886.06	885.64	885.64	884.51	884.51	884.36	
PROPOSED ELEV		884.05	884.55	884.67	885.94	885.94	886.25	886.55	886.86	886.56	886.25	885.95	885.95	884.74	884.61	884.11	
MILLED ELEV				884.40	885.56	885.35	885.75	886.05	886.36	886.06	885.75	885.39	885.60	884.47			
MILLED DEPTH (IN)				0.50	0.50	3.00	3.38	3.85	4.14	4.05	3.71	3.00	0.50	0.50			
PAVEMENT DEPTH (IN)				3.29	4.58	7.08	6.00	6.00	6.00	6.00	6.00	6.62	4.12	3.29			
TOP LIFT (IN)				2.00	2.00	2.50	2.50	2.50	2.50	2.50	2.50	2.50	2.00	2.00			
LIFT						2.50	2.50	2.50	2.50	2.50	2.50	2.50					
VARIABLE DEPTH LIFT (IN)				1.29	2.58	2.08	1.00	1.00	1.00	1.00	1.00	1.62	2.12	1.29			

	OFFSET LEFT	110' LEFT (TURF)	SHOULDER EDGE LEFT (TURF)	SHOULDER EDGE LEFT (PAVEMENT)	75' LEFT (SHOULDER)	75' LEFT (RUNWAY)	50' LEFT	25' LEFT	CENTERLINE	25' RIGHT	50' RIGHT	75' RIGHT (RUNWAY)	75' RIGHT (SHOULDER)	SHOULDER EDGE RIGHT (PAVEMENT)	SHOULDER EDGE RIGHT (TURF)	110' RIGHT (TURF)	OFFSET RIGHT
177+50																	
MATCH EXISTING	111.75																148.96
EXISTING ELEV		884.14	884.39	884.39	885.53	885.53	885.97	886.31	886.65	886.33	886.01	885.59	885.59	884.44	884.44	884.29	
PROPOSED ELEV		883.99	884.49	884.61	885.91	885.91	886.20	886.49	886.78	886.48	886.18	885.88	885.88	884.67	884.54	884.04	
MILLED ELEV				884.35	885.49	885.28	885.70	885.99	886.28	885.98	885.68	885.34	885.55	884.40			
MILLED DEPTH (IN)				0.50	0.50	3.00	3.24	3.85	4.36	4.23	3.92	3.00	0.50	0.50			
PAVEMENT DEPTH (IN)				3.09	5.03	7.53	6.00	6.00	6.00	6.00	6.00	6.48	3.98	3.19			
TOP LIFT (IN)				2.00	2.00	2.50	2.50	2.50	2.50	2.50	2.50	2.50	2.00	2.00			
LIFT						2.50	2.50	2.50	2.50	2.50	2.50	2.50					
VARIABLE DEPTH LIFT (IN)				1.09	3.03	2.53	1.00	1.00	1.00	1.00	1.00	1.48	1.98	1.19			

	OFFSET LEFT	110' LEFT (TURF)	SHOULDER EDGE LEFT (TURF)	SHOULDER EDGE LEFT (PAVEMENT)	75' LEFT (SHOULDER)	75' LEFT (RUNWAY)	50' LEFT	25' LEFT	CENTERLINE	25' RIGHT	50' RIGHT	75' RIGHT (RUNWAY)	75' RIGHT (SHOULDER)	SHOULDER EDGE RIGHT (PAVEMENT)	SHOULDER EDGE RIGHT (TURF)	110' RIGHT (TURF)	OFFSET RIGHT
177+75																	
MATCH EXISTING	112.23																149.78
EXISTING ELEV		884.10	884.37	884.37	885.45	885.45	885.90	886.25	886.59	886.28	885.96	885.55	885.55	884.40	884.40	884.12	
PROPOSED ELEV		883.93	884.43	884.55	885.88	885.88	886.16	886.43	886.71	886.43	886.14	885.85	885.85	884.59	884.47	883.97	
MILLED ELEV				884.32	885.41	885.20	885.65	885.93	886.21	885.93	885.64	885.30	885.50	884.36			
MILLED DEPTH (IN)				0.50	0.50	3.00	3.00	3.85	4.56	4.31	3.88	3.00	0.50	0.50			
PAVEMENT DEPTH (IN)				2.74	5.60	8.10	6.04	6.00	6.00	6.00	6.00	6.71	4.21	2.78			
TOP LIFT (IN)				2.00	2.00	2.50	2.50	2.50	2.50	2.50	2.50	2.50	2.00	2.00			
LIFT						2.50	2.50	2.50	2.50	2.50	2.50	2.50					
VARIABLE DEPTH LIFT (IN)				0.74	3.60	3.10	1.04	1.00	1.00	1.00	1.00	1.71	2.21	0.78			
178+00																	
MATCH EXISTING	113.80																147.18
EXISTING ELEV		884.13	884.25	884.25	885.40	885.40	885.86	886.20	886.55	886.25	885.92	885.50	885.50	884.36	884.36	884.29	
PROPOSED ELEV		883.90	884.40	884.52	885.85	885.85	886.13	886.41	886.68	886.40	886.11	885.83	885.83	884.52	884.40	883.90	
MILLED ELEV				884.20	885.36	885.15	885.61	885.91	886.18	885.90	885.61	885.25	885.46	884.32			
MILLED DEPTH (IN)				0.50	0.50	3.00	3.00	3.55	4.45	4.27	3.67	3.00	0.50	0.50			
PAVEMENT DEPTH (IN)				3.85	5.91	8.41	6.28	6.00	6.00	6.00	6.00	6.95	4.45	2.50			
TOP LIFT (IN)				2.00	2.00	2.50	2.50	2.50	2.50	2.50	2.50	2.50	2.00	2.00			
LIFT						2.50	2.50	2.50	2.50	2.50	2.50	2.50					
VARIABLE DEPTH LIFT (IN)				1.85	3.91	3.41	1.28	1.00	1.00	1.00	1.00	1.95	2.45	0.50			
178+25																	
MATCH EXISTING	109.34																144.58
EXISTING ELEV		883.92	884.18	884.18	885.38	885.38	885.83	886.17	886.51	886.22	885.88	885.47	885.47	884.31	884.31	884.19	
PROPOSED ELEV		883.87	884.37	884.49	885.83	885.83	886.10	886.38	886.66	886.37	886.09	885.80	885.80	884.48	884.36	883.86	
MILLED ELEV				884.14	885.34	885.13	885.58	885.88	886.16	885.87	885.59	885.22	885.43	884.27			
MILLED DEPTH (IN)				0.50	0.50	3.00	3.00	3.44	4.22	4.15	3.49	3.00	0.50	0.50			
PAVEMENT DEPTH (IN)				4.22	5.90	8.40	6.30	6.00	6.00	6.00	6.00	6.98	4.48	2.55			
TOP LIFT (IN)				2.00	2.00	2.50	2.50	2.50	2.50	2.50	2.50	2.50	2.00	2.00			
LIFT						2.50	2.50	2.50	2.50	2.50	2.50	2.50					
VARIABLE DEPTH LIFT (IN)				2.22	3.90	3.40	1.30	1.00	1.00	1.00	1.00	1.98	2.48	0.55			
178+50																	
MATCH EXISTING	110.55																141.98
EXISTING ELEV		883.91	884.17	884.17	885.36	885.36	885.80	886.14	886.48	886.18	885.84	885.42	885.42	884.28	884.28	884.20	
PROPOSED ELEV		883.84	884.34	884.47	885.80	885.80	886.08	886.35	886.63	886.35	886.06	885.78	885.78	884.44	884.32	883.82	
MILLED ELEV				884.13	885.32	885.11	885.55	885.85	886.13	885.85	885.56	885.17	885.38	884.23			
MILLED DEPTH (IN)				0.50	0.50	3.00	3.00	3.47	4.20	3.97	3.36	3.00	0.50	0.50			

PAVEMENT DEPTH (IN)				4.09	5.80	8.30	6.32	6.00	6.00	6.00	6.00	7.27	4.77	2.48			
TOP LIFT (IN)				2.00	2.00	2.50	2.50	2.50	2.50	2.50	2.50	2.50	2.00	2.00			
LIFT						2.50	2.50	2.50	2.50	2.50	2.50	2.50					
VARIABLE DEPTH LIFT (IN)				2.09	3.80	3.30	1.32	1.00	1.00	1.00	1.00	2.27	2.77	0.48			

	OFFSET LEFT	110' LEFT (TURF)	SHOULDER EDGE LEFT (TURF)	SHOULDER EDGE LEFT (PAVEMENT)	75' LEFT (SHOULDER)	75' LEFT (RUNWAY)	50' LEFT	25' LEFT	CENTERLINE	25' RIGHT	50' RIGHT	75' RIGHT (RUNWAY)	75' RIGHT (SHOULDER)	SHOULDER EDGE RIGHT (PAVEMENT)	SHOULDER EDGE RIGHT (TURF)	110' RIGHT (TURF)	OFFSET RIGHT
--	-------------	------------------	---------------------------	-------------------------------	---------------------	-------------------	----------	----------	------------	-----------	-----------	--------------------	----------------------	--------------------------------	----------------------------	-------------------	--------------

178+75

MATCH EXISTING	110.61																149.33
EXISTING ELEV		883.89	884.11	884.11	885.33	885.33	885.78	886.12	886.45	886.15	885.81	885.39	885.39	884.21	884.21	884.01	
PROPOSED ELEV		883.82	884.32	884.44	885.78	885.78	886.05	886.33	886.60	886.32	886.04	885.75	885.75	884.40	884.28	883.78	
MILLED ELEV				884.07	885.29	885.08	885.53	885.83	886.10	885.82	885.54	885.14	885.35	884.16			
MILLED DEPTH (IN)				0.50	0.50	3.00	3.00	3.50	4.17	3.92	3.30	3.00	0.50	0.50			
PAVEMENT DEPTH (IN)				4.49	5.86	8.36	6.31	6.00	6.00	6.00	6.00	7.36	4.86	2.88			
TOP LIFT (IN)				2.00	2.00	2.50	2.50	2.50	2.50	2.50	2.50	2.50	2.00	2.00			
LIFT						2.50	2.50	2.50	2.50	2.50	2.50	2.50					
VARIABLE DEPTH LIFT (IN)				2.49	3.86	3.36	1.31	1.00	1.00	1.00	1.00	2.36	2.86	0.88			

	OFFSET LEFT	110' LEFT (TURF)	SHOULDER EDGE LEFT (TURF)	SHOULDER EDGE LEFT (PAVEMENT)	75' LEFT (SHOULDER)	75' LEFT (RUNWAY)	50' LEFT	25' LEFT	CENTERLINE	25' RIGHT	50' RIGHT	75' RIGHT (RUNWAY)	75' RIGHT (SHOULDER)	SHOULDER EDGE RIGHT (PAVEMENT)	SHOULDER EDGE RIGHT (TURF)	110' RIGHT (TURF)	OFFSET RIGHT
--	-------------	------------------	---------------------------	-------------------------------	---------------------	-------------------	----------	----------	------------	-----------	-----------	--------------------	----------------------	--------------------------------	----------------------------	-------------------	--------------

179+00

MATCH EXISTING	111.42																140.53
EXISTING ELEV		883.88	884.10	884.10	885.31	885.31	885.75	886.08	886.41	886.12	885.78	885.38	885.38	884.20	884.20	884.09	
PROPOSED ELEV		883.79	884.29	884.41	885.75	885.75	886.03	886.30	886.58	886.29	886.01	885.73	885.73	884.37	884.24	883.75	
MILLED ELEV				884.06	885.27	885.06	885.50	885.80	886.08	885.79	885.51	885.13	885.34	884.16			
MILLED DEPTH (IN)				0.50	0.50	3.00	3.00	3.34	4.06	3.89	3.24	3.00	0.50	0.50			
PAVEMENT DEPTH (IN)				4.21	5.83	8.33	6.36	6.00	6.00	6.00	6.00	7.16	4.66	2.53			
TOP LIFT (IN)				2.00	2.00	2.50	2.50	2.50	2.50	2.50	2.50	2.50	2.00	2.00			
LIFT						2.50	2.50	2.50	2.50	2.50	2.50	2.50					
VARIABLE DEPTH LIFT (IN)				2.21	3.83	3.33	1.36	1.00	1.00	1.00	1.00	2.16	2.66	0.53			

	OFFSET LEFT	110' LEFT (TURF)	SHOULDER EDGE LEFT (TURF)	SHOULDER EDGE LEFT (PAVEMENT)	75' LEFT (SHOULDER)	75' LEFT (RUNWAY)	50' LEFT	25' LEFT	CENTERLINE	25' RIGHT	50' RIGHT	75' RIGHT (RUNWAY)	75' RIGHT (SHOULDER)	SHOULDER EDGE RIGHT (PAVEMENT)	SHOULDER EDGE RIGHT (TURF)	110' RIGHT (TURF)	OFFSET RIGHT
--	-------------	------------------	---------------------------	-------------------------------	---------------------	-------------------	----------	----------	------------	-----------	-----------	--------------------	----------------------	--------------------------------	----------------------------	-------------------	--------------

179+25

MATCH EXISTING	111.13																143.92
EXISTING ELEV		883.85	884.07	884.07	885.25	885.25	885.71	886.05	886.38	886.09	885.75	885.31	885.31	884.17	884.17	883.91	
PROPOSED ELEV		883.76	884.26	884.38	885.73	885.73	886.00	886.27	886.55	886.27	885.99	885.70	885.70	884.34	884.22	883.72	
MILLED ELEV				884.03	885.21	885.00	885.46	885.77	886.05	885.77	885.49	885.06	885.27	884.12			
MILLED DEPTH (IN)				0.50	0.50	3.00	3.00	3.25	3.97	3.83	3.18	3.00	0.50	0.50			
PAVEMENT DEPTH (IN)				4.25	6.20	8.70	6.52	6.00	6.00	6.00	6.00	7.68	5.18	2.62			
TOP LIFT (IN)				2.00	2.00	2.50	2.50	2.50	2.50	2.50	2.50	2.50	2.00	2.00			
LIFT						2.50	2.50	2.50	2.50	2.50	2.50	2.50					
VARIABLE DEPTH LIFT (IN)				2.25	4.20	3.70	1.52	1.00	1.00	1.00	1.00	2.68	3.18	0.62			

	OFFSET LEFT	110' LEFT (TURF)	SHOULDER EDGE LEFT (TURF)	SHOULDER EDGE LEFT (PAVEMENT)	75' LEFT (SHOULDER)	75' LEFT (RUNWAY)	50' LEFT	25' LEFT	CENTERLINE	25' RIGHT	50' RIGHT	75' RIGHT (RUNWAY)	75' RIGHT (SHOULDER)	SHOULDER EDGE RIGHT (PAVEMENT)	SHOULDER EDGE RIGHT (TURF)	110' RIGHT (TURF)	OFFSET RIGHT
--	-------------	------------------	---------------------------	-------------------------------	---------------------	-------------------	----------	----------	------------	-----------	-----------	--------------------	----------------------	--------------------------------	----------------------------	-------------------	--------------

179+50

MATCH EXISTING	109.49																138.36
EXISTING ELEV		883.78	884.05	884.05	885.23	885.23	885.68	886.02	886.36	886.04	885.71	885.28	885.28	884.09	884.09	883.94	
PROPOSED ELEV		883.73	884.23	884.36	885.72	885.72	885.99	886.26	886.52	886.24	885.96	885.68	885.68	884.31	884.19	883.69	
MILLED ELEV				884.00	885.18	884.98	885.43	885.76	886.02	885.74	885.46	885.03	885.24	884.05			
MILLED DEPTH (IN)				0.50	0.50	3.00	3.00	3.15	4.01	3.64	3.00	3.00	0.50	0.50			
PAVEMENT DEPTH (IN)				4.22	6.47	8.97	6.72	6.00	6.00	6.00	6.01	7.78	5.28	3.14			
TOP LIFT (IN)				2.00	2.00	2.50	2.50	2.50	2.50	2.50	2.50	2.50	2.00	2.00			
LIFT						2.50	2.50	2.50	2.50	2.50	2.50	2.50					
VARIABLE DEPTH LIFT (IN)				2.22	4.47	3.97	1.72	1.00	1.00	1.00	1.01	2.78	3.28	1.14			

	OFFSET LEFT	110' LEFT (TURF)	SHOULDER EDGE LEFT (TURF)	SHOULDER EDGE LEFT (PAVEMENT)	75' LEFT (SHOULDER)	75' LEFT (RUNWAY)	50' LEFT	25' LEFT	CENTERLINE	25' RIGHT	50' RIGHT	75' RIGHT (RUNWAY)	75' RIGHT (SHOULDER)	SHOULDER EDGE RIGHT (PAVEMENT)	SHOULDER EDGE RIGHT (TURF)	110' RIGHT (TURF)	OFFSET RIGHT
179+75																	
MATCH EXISTING	113.39																137.07
EXISTING ELEV		883.82	884.08	884.08	885.24	885.24	885.68	886.01	886.34	886.02	885.67	885.21	885.21	884.05	884.05	883.88	
PROPOSED ELEV		883.72	884.21	884.34	885.72	885.72	885.98	886.24	886.50	886.21	885.93	885.66	885.66	884.29	884.16	883.66	
MILLED ELEV				884.04	885.20	884.99	885.43	885.74	886.00	885.71	885.42	884.96	885.17	884.01			
MILLED DEPTH (IN)				0.50	0.50	3.00	3.00	3.32	4.10	3.61	3.00	3.00	0.50	0.50			
PAVEMENT DEPTH (IN)				3.62	6.26	8.76	6.57	6.00	6.00	6.00	6.13	8.38	5.88	3.30			
TOP LIFT (IN)				2.00	2.00	2.50	2.50	2.50	2.50	2.50	2.50	2.50	2.00	2.00			
LIFT						2.50	2.50	2.50	2.50	2.50	2.50	2.50					
VARIABLE DEPTH LIFT (IN)				1.62	4.26	3.76	1.57	1.00	1.00	1.00	1.13	3.38	3.88	1.30			

	OFFSET LEFT	110' LEFT (TURF)	SHOULDER EDGE LEFT (TURF)	SHOULDER EDGE LEFT (PAVEMENT)	75' LEFT (SHOULDER)	75' LEFT (RUNWAY)	50' LEFT	25' LEFT	CENTERLINE	25' RIGHT	50' RIGHT	75' RIGHT (RUNWAY)	75' RIGHT (SHOULDER)	SHOULDER EDGE RIGHT (PAVEMENT)	SHOULDER EDGE RIGHT (TURF)	110' RIGHT (TURF)	OFFSET RIGHT
180+00																	
MATCH EXISTING	121.99																134.57
EXISTING ELEV		883.90	884.11	884.11	885.25	885.25	885.68	886.00	886.32	886.01	885.66	885.21	885.21	884.06	884.06	884.05	
PROPOSED ELEV		883.76	884.26	884.38	885.72	885.72	885.97	886.23	886.48	886.21	885.93	885.65	885.65	884.26	884.13	883.63	
MILLED ELEV				884.07	885.21	885.00	885.43	885.73	885.98	885.71	885.41	884.96	885.17	884.01			
MILLED DEPTH (IN)				0.50	0.50	3.00	3.00	3.26	4.03	3.63	3.00	3.00	0.50	0.50			
PAVEMENT DEPTH (IN)				3.74	6.07	8.57	6.54	6.00	6.00	6.00	6.22	8.30	5.80	2.91			
TOP LIFT (IN)				2.00	2.00	2.50	2.50	2.50	2.50	2.50	2.50	2.50	2.00	2.00			
LIFT						2.50	2.50	2.50	2.50	2.50	2.50	2.50					
VARIABLE DEPTH LIFT (IN)				1.74	4.07	3.57	1.54	1.00	1.00	1.00	1.22	3.30	3.80	0.91			

	OFFSET LEFT	110' LEFT (TURF)	SHOULDER EDGE LEFT (TURF)	SHOULDER EDGE LEFT (PAVEMENT)	75' LEFT (SHOULDER)	75' LEFT (RUNWAY)	50' LEFT	25' LEFT	CENTERLINE	25' RIGHT	50' RIGHT	75' RIGHT (RUNWAY)	75' RIGHT (SHOULDER)	SHOULDER EDGE RIGHT (PAVEMENT)	SHOULDER EDGE RIGHT (TURF)	110' RIGHT (TURF)	OFFSET RIGHT
180+25																	
MATCH EXISTING	120.79																126.62
EXISTING ELEV		883.93	884.16	884.16	885.24	885.24	885.67	885.98	886.30	886.01	885.66	885.20	885.20	884.05	884.05	883.83	
PROPOSED ELEV		883.80	884.30	884.43	885.72	885.72	885.97	886.23	886.48	886.21	885.93	885.65	885.65	884.23	884.10	883.60	
MILLED ELEV				884.12	885.20	884.99	885.42	885.73	885.98	885.71	885.41	884.95	885.16	884.01			
MILLED DEPTH (IN)				0.50	0.50	3.00	3.00	3.10	3.76	3.70	3.00	3.00	0.50	0.50			
PAVEMENT DEPTH (IN)				3.67	6.24	8.74	6.64	6.00	6.00	6.00	6.26	8.46	5.96	2.59			
TOP LIFT (IN)				2.00	2.00	2.50	2.50	2.50	2.50	2.50	2.50	2.50	2.00	2.00			
LIFT						2.50	2.50	2.50	2.50	2.50	2.50	2.50					
VARIABLE DEPTH LIFT (IN)				1.67	4.24	3.74	1.64	1.00	1.00	1.00	1.26	3.46	3.96	0.59			

	OFFSET LEFT	110' LEFT (TURF)	SHOULDER EDGE LEFT (TURF)	SHOULDER EDGE LEFT (PAVEMENT)	75' LEFT (SHOULDER)	75' LEFT (RUNWAY)	50' LEFT	25' LEFT	CENTERLINE	25' RIGHT	50' RIGHT	75' RIGHT (RUNWAY)	75' RIGHT (SHOULDER)	SHOULDER EDGE RIGHT (PAVEMENT)	SHOULDER EDGE RIGHT (TURF)	110' RIGHT (TURF)	OFFSET RIGHT
180+50																	
MATCH EXISTING	109.24																116.03
EXISTING ELEV		883.88	884.23	884.23	885.24	885.24	885.66	885.98	886.30	886.00	885.65	885.20	885.20	884.04	884.04	883.78	
PROPOSED ELEV		883.85	884.35	884.47	885.71	885.71	885.97	886.22	886.48	886.20	885.93	885.65	885.65	884.22	884.09	883.59	
MILLED ELEV				884.19	885.20	884.99	885.41	885.72	885.98	885.70	885.40	884.95	885.16	884.00			
MILLED DEPTH (IN)				0.50	0.50	3.00	3.00	3.13	3.80	3.61	3.00	3.00	0.50	0.50			
PAVEMENT DEPTH (IN)				3.42	6.17	8.67	6.70	6.00	6.00	6.00	6.30	8.45	5.95	2.61			
TOP LIFT (IN)				2.00	2.00	2.50	2.50	2.50	2.50	2.50	2.50	2.50	2.00	2.00			
LIFT						2.50	2.50	2.50	2.50	2.50	2.50	2.50					
VARIABLE DEPTH LIFT (IN)				1.42	4.17	3.67	1.70	1.00	1.00	1.00	1.30	3.45	3.95	0.61			
180+75																	
MATCH EXISTING	108.97																115.31
EXISTING ELEV		883.88	884.30	884.30	885.29	885.29	885.69	885.98	886.28	885.98	885.64	885.19	885.19	884.05	884.05	883.77	
PROPOSED ELEV		883.89	884.39	884.52	885.71	885.71	885.97	886.22	886.48	886.20	885.93	885.65	885.65	884.21	884.09	883.59	
MILLED ELEV				884.26	885.25	885.04	885.44	885.72	885.98	885.70	885.39	884.94	885.15	884.01			
MILLED DEPTH (IN)				0.50	0.50	3.00	3.00	3.11	3.61	3.33	3.00	3.00	0.50	0.50			
PAVEMENT DEPTH (IN)				3.08	5.52	8.02	6.38	6.00	6.00	6.42	8.50	6.00	2.45	2.45			
TOP LIFT (IN)				2.00	2.00	2.50	2.50	2.50	2.50	2.50	2.50	2.50	2.00	2.00			
LIFT						2.50	2.50	2.50	2.50	2.50	2.50	2.50					
VARIABLE DEPTH LIFT (IN)				1.08	3.52	3.02	1.38	1.00	1.00	1.00	1.42	3.50	4.00	0.45			
181+00																	
MATCH EXISTING	111.81																116.78
EXISTING ELEV		884.03	884.45	884.45	885.39	885.39	885.72	885.98	886.27	885.96	885.62	885.19	885.19	884.04	884.04	883.76	
PROPOSED ELEV		883.94	884.44	884.57	885.71	885.71	885.96	886.22	886.47	886.20	885.92	885.65	885.65	884.21	884.08	883.58	
MILLED ELEV				884.40	885.35	885.14	885.46	885.72	885.97	885.70	885.37	884.94	885.15	883.99			
MILLED DEPTH (IN)				0.58	0.50	3.00	3.06	3.11	3.49	3.11	3.00	3.00	0.50	0.50			
PAVEMENT DEPTH (IN)				2.00	4.33	6.83	6.00	6.00	6.00	6.00	6.58	8.52	6.02	2.56			
TOP LIFT (IN)				2.00	2.00	2.50	2.50	2.50	2.50	2.50	2.50	2.50	2.00	2.00			
LIFT						2.50	2.50	2.50	2.50	2.50	2.50	2.50					
VARIABLE DEPTH LIFT (IN)				0.00	2.33	1.83	1.00	1.00	1.00	1.00	1.58	3.52	4.02	0.56			
181+25																	
MATCH EXISTING	113.46																114.47
EXISTING ELEV		884.00	884.49	884.49	885.45	885.45	885.74	885.98	886.25	885.95	885.61	885.17	885.17	883.99	883.99	883.67	
PROPOSED ELEV		884.00	884.50	884.62	885.71	885.71	885.96	886.22	886.47	886.20	885.92	885.65	885.65	884.20	884.08	883.58	
MILLED ELEV				884.45	885.40	885.20	885.46	885.72	885.97	885.70	885.36	884.92	885.13	883.95			
MILLED DEPTH (IN)				0.50	0.50	3.00	3.30	3.16	3.39	3.02	3.00	3.00	0.50	0.50			

PAVEMENT DEPTH (IN)				2.14	3.62	6.12	6.00	6.00	6.00	6.00	6.79	8.71	6.21	3.02			
TOP LIFT (IN)				2.00	2.00	2.50	2.50	2.50	2.50	2.50	2.50	2.50	2.50	2.00	2.00		
LIFT						2.50	2.50	2.50	2.50	2.50	2.50	2.50					
VARIABLE DEPTH LIFT (IN)				0.14	1.62	1.12	1.00	1.00	1.00	1.00	1.79	3.71	4.21	1.02			
	OFFSET LEFT	110' LEFT (TURF)	SHOULDER EDGE LEFT (TURF)	SHOULDER EDGE LEFT (PAVEMENT)	75' LEFT (SHOULDER)	75' LEFT (RUNWAY)	50' LEFT	25' LEFT	CENTERLINE	25' RIGHT	50' RIGHT	75' RIGHT (RUNWAY)	75' RIGHT (SHOULDER)	SHOULDER EDGE RIGHT (PAVEMENT)	SHOULDER EDGE RIGHT (TURF)	110' RIGHT (TURF)	OFFSET RIGHT
181+50																	
MATCH EXISTING	112.76																120.87
EXISTING ELEV			884.50	884.50	885.43	885.43	885.74	885.99	886.25	885.94	885.58	885.10	885.10	884.05			
PROPOSED ELEV			884.57	884.70	885.70	885.70	885.96	886.21	886.47	886.19	885.92	885.65	885.65	884.15			
MILLED ELEV				884.46	885.39	885.18	885.46	885.71	885.97	885.69	885.33	884.85	885.06	883.99			
MILLED DEPTH (IN)				0.50	0.50	3.00	3.41	3.28	3.39	3.00	3.00	3.00	0.50	0.74			
PAVEMENT DEPTH (IN)				2.91	3.80	6.30	6.00	6.00	6.00	6.02	7.10	9.57	7.07	2.00			
TOP LIFT (IN)				2.00	2.00	2.50	2.50	2.50	2.50	2.50	2.50	2.50	2.00	2.00			
LIFT						2.50	2.50	2.50	2.50	2.50	2.50	2.50					
VARIABLE DEPTH LIFT (IN)				0.91	1.80	1.30	1.00	1.00	1.00	1.02	2.10	4.57	5.07	0.00			
	OFFSET LEFT	110' LEFT (TURF)	SHOULDER EDGE LEFT (TURF)	SHOULDER EDGE LEFT (PAVEMENT)	75' LEFT (SHOULDER)	75' LEFT (RUNWAY)	50' LEFT	25' LEFT	CENTERLINE	25' RIGHT	50' RIGHT	75' RIGHT (RUNWAY)	75' RIGHT (SHOULDER)	100' RIGHT	125' RIGHT		OFFSET RIGHT
181+75																	
MATCH EXISTING	105.02																134.53
EXISTING ELEV			884.63	884.63	885.45	885.45	885.73	885.98	886.24	885.92	885.56	885.05	885.05	884.04	883.00		
PROPOSED ELEV			884.66	884.78	885.70	885.70	885.96	886.21	886.47	886.19	885.92	885.64	885.64	884.30	883.11		
MILLED ELEV				884.59	885.41	885.20	885.46	885.71	885.97	885.67	885.31	884.80	885.01	884.00	882.95		
MILLED DEPTH (IN)				0.50	0.50	3.01	3.24	3.26	3.29	3.00	3.00	3.00	0.50	0.50	0.59		
PAVEMENT DEPTH (IN)				2.32	3.49	6.00	6.00	6.00	6.00	6.31	7.30	10.12	7.62	3.60	2.00		
TOP LIFT (IN)				2.00	2.00	2.50	2.50	2.50	2.50	2.50	2.50	2.50	2.00	2.00	2.00		
LIFT						2.50	2.50	2.50	2.50	2.50	2.50	2.50					
VARIABLE DEPTH LIFT (IN)				0.32	1.49	1.00	1.00	1.00	1.00	1.31	2.30	5.12	5.62	1.60	0.00		
	OFFSET LEFT	110' LEFT (TURF)	SHOULDER EDGE LEFT (TURF)	SHOULDER EDGE LEFT (PAVEMENT)	75' LEFT (SHOULDER)	75' LEFT (RUNWAY)	50' LEFT	25' LEFT	CENTERLINE	25' RIGHT	50' RIGHT	75' RIGHT (RUNWAY)	75' RIGHT (SHOULDER)	100' RIGHT	125' RIGHT		OFFSET RIGHT
182+00																	
MATCH EXISTING	99.27																144.98
EXISTING ELEV					885.45	885.45	885.72	885.98	886.23	885.91	885.56	885.14	885.14	884.49	883.79		
PROPOSED ELEV					885.70	885.70	885.95	886.21	886.46	886.19	885.92	885.64	885.64	884.71	883.86		
MILLED ELEV					885.41	885.20	885.45	885.71	885.96	885.66	885.31	884.89	885.10	884.45	883.69		
MILLED DEPTH (IN)					0.50	3.00	3.13	3.25	3.22	3.00	3.00	3.00	0.50	0.50	1.17		
PAVEMENT DEPTH (IN)					3.52	6.02	6.00	6.00	6.00	6.40	7.32	9.06	6.56	3.14	2.00		
TOP LIFT (IN)					2.00	2.50	2.50	2.50	2.50	2.50	2.50	2.50	2.00	2.00	2.00		
LIFT						2.50	2.50	2.50	2.50	2.50	2.50	2.50					
VARIABLE DEPTH LIFT (IN)					1.52	1.02	1.00	1.00	1.00	1.40	2.32	4.06	4.56	1.14	0.00		
	OFFSET LEFT	110' LEFT (TURF)	SHOULDER EDGE LEFT (TURF)	SHOULDER EDGE LEFT (PAVEMENT)	75' LEFT (SHOULDER)	75' LEFT (RUNWAY)	50' LEFT	25' LEFT	CENTERLINE	25' RIGHT	50' RIGHT	75' RIGHT (RUNWAY)	75' RIGHT (SHOULDER)	100' RIGHT	125' RIGHT		OFFSET RIGHT
182+25																	

MATCH EXISTING	99.56																145.06
EXISTING ELEV					885.49	885.49	885.72	885.97	886.22	885.90	885.56	885.17	885.17	884.75	884.08		
PROPOSED ELEV					885.70	885.70	885.95	886.21	886.46	886.19	885.91	885.64	885.64	884.98	884.29		
MILLED ELEV					885.45	885.20	885.45	885.71	885.96	885.65	885.31	884.92	885.13	884.71	884.04		
MILLED DEPTH (IN)					0.50	3.51	3.24	3.12	3.15	3.00	3.00	3.00	0.50	0.50	0.50		
PAVEMENT DEPTH (IN)					2.99	6.00	6.00	6.00	6.00	6.43	7.29	8.68	6.18	3.27	3.02		
TOP LIFT (IN)					2.00	2.50	2.50	2.50	2.50	2.50	2.50	2.50	2.00	2.00	2.00		
LIFT						2.50	2.50	2.50	2.50	2.50	2.50	2.50					
VARIABLE DEPTH LIFT (IN)					0.99	1.00	1.00	1.00	1.00	1.43	2.29	3.68	4.18	1.27	1.02		

	OFFSET LEFT	110' LEFT (TURF)	SHOULDER EDGE LEFT (TURF)	SHOULDER EDGE LEFT (PAVEMENT)	75' LEFT (SHOULDER)	75' LEFT (RUNWAY)	50' LEFT	25' LEFT	CENTERLINE	25' RIGHT	50' RIGHT	75' RIGHT (RUNWAY)	75' RIGHT (SHOULDER)	100' RIGHT	125' RIGHT		OFFSET RIGHT
182+50																	
MATCH EXISTING	99.85																145.14
EXISTING ELEV					885.46	885.46	885.71	885.95	886.21	885.91	885.57	885.18	885.18	884.83	884.43		
PROPOSED ELEV					885.70	885.70	885.95	886.20	886.46	886.19	885.91	885.64	885.64	885.10	884.55		
MILLED ELEV					885.42	885.20	885.45	885.70	885.96	885.66	885.32	884.93	885.14	884.79	884.38		
MILLED DEPTH (IN)					0.50	3.14	3.16	3.00	3.00	3.00	3.00	3.00	0.50	0.50	0.61		
PAVEMENT DEPTH (IN)					3.36	6.00	6.00	6.06	6.00	6.35	7.15	8.54	6.04	3.76	2.00		
TOP LIFT (IN)					2.00	2.50	2.50	2.50	2.50	2.50	2.50	2.50	2.00	2.00	2.00		
LIFT						2.50	2.50	2.50	2.50	2.50	2.50	2.50					
VARIABLE DEPTH LIFT (IN)					1.36	1.00	1.00	1.06	1.00	1.35	2.15	3.54	4.04	1.76	0.00		

	OFFSET LEFT	110' LEFT (TURF)	SHOULDER EDGE LEFT (TURF)	SHOULDER EDGE LEFT (PAVEMENT)	75' LEFT (SHOULDER)	75' LEFT (RUNWAY)	50' LEFT	25' LEFT	CENTERLINE	25' RIGHT	50' RIGHT	75' RIGHT (RUNWAY)	75' RIGHT (SHOULDER)	100' RIGHT	125' RIGHT		OFFSET RIGHT
182+75																	
MATCH EXISTING	99.95																145.22
EXISTING ELEV					885.49	885.49	885.74	885.96	886.20	885.93	885.60	885.25	885.25	884.78	884.39		
PROPOSED ELEV					885.69	885.69	885.95	886.20	886.46	886.18	885.91	885.64	885.64	885.08	884.51		
MILLED ELEV					885.44	885.19	885.45	885.70	885.95	885.68	885.35	885.00	885.21	884.74	884.34		
MILLED DEPTH (IN)					0.50	3.52	3.50	3.10	3.00	3.00	3.00	3.00	0.50	0.50	0.58		
PAVEMENT DEPTH (IN)					2.98	6.00	6.00	6.00	6.12	6.03	6.74	7.66	5.16	4.16	2.00		
TOP LIFT (IN)					2.00	2.50	2.50	2.50	2.50	2.50	2.50	2.50	2.00	2.00	2.00		
LIFT						2.50	2.50	2.50	2.50	2.50	2.50	2.50					
VARIABLE DEPTH LIFT (IN)					0.98	1.00	1.00	1.00	1.12	1.03	1.74	2.66	3.16	2.16	0.00		

	OFFSET LEFT	110' LEFT (TURF)	SHOULDER EDGE LEFT (TURF)	SHOULDER EDGE LEFT (PAVEMENT)	75' LEFT (SHOULDER)	75' LEFT (RUNWAY)	50' LEFT	25' LEFT	CENTERLINE	25' RIGHT	50' RIGHT	75' RIGHT (RUNWAY)	75' RIGHT (SHOULDER)	100' RIGHT	125' RIGHT		OFFSET RIGHT
183+00																	
MATCH EXISTING	99.87																145.30
EXISTING ELEV					885.53	885.53	885.75	885.99	886.22	885.96	885.63	885.30	885.30	884.67	884.09		
PROPOSED ELEV					885.69	885.69	885.95	886.20	886.45	886.18	885.91	885.64	885.64	884.95	884.27		
MILLED ELEV					885.49	885.19	885.45	885.70	885.95	885.68	885.38	885.05	885.26	884.63	884.04		
MILLED DEPTH (IN)					0.50	4.09	3.72	3.46	3.23	3.39	3.00	3.00	0.50	0.50	0.50		
PAVEMENT DEPTH (IN)					2.41	6.00	6.00	6.00	6.00	6.00	6.33	7.04	4.54	3.84	2.70		
TOP LIFT (IN)					2.00	2.50	2.50	2.50	2.50	2.50	2.50	2.50	2.00	2.00	2.00		
LIFT						2.50	2.50	2.50	2.50	2.50	2.50	2.50					
VARIABLE DEPTH LIFT (IN)					0.41	1.00	1.00	1.00	1.00	1.00	1.33	2.04	2.54	1.84	0.70		

	OFFSET LEFT	110' LEFT (TURF)	SHOULDER EDGE LEFT (TURF)	SHOULDER EDGE LEFT (PAVEMENT)	75' LEFT (SHOULDER)	75' LEFT (RUNWAY)	50' LEFT	25' LEFT	CENTERLINE	25' RIGHT	50' RIGHT	75' RIGHT (RUNWAY)	75' RIGHT (SHOULDER)	100' RIGHT	125' RIGHT	OFFSET RIGHT
183+25																
MATCH EXISTING	99.80															145.37
EXISTING ELEV					885.47	885.47	885.76	886.00	886.23	885.97	885.65	885.30	885.30	884.61	883.84	
PROPOSED ELEV					885.69	885.69	885.94	886.20	886.45	886.18	885.91	885.63	885.63	884.72	883.83	
MILLED ELEV					885.43	885.19	885.44	885.70	885.95	885.68	885.40	885.05	885.25	884.55	883.67	
MILLED DEPTH (IN)					0.50	3.42	3.76	3.64	3.37	3.44	3.00	3.00	0.50	0.67	2.05	
PAVEMENT DEPTH (IN)					3.08	6.00	6.00	6.00	6.00	6.00	6.09	7.06	4.56	2.00	2.00	
TOP LIFT (IN)					2.00	2.50	2.50	2.50	2.50	2.50	2.50	2.50	2.00	2.00	2.00	
LIFT						2.50	2.50	2.50	2.50	2.50	2.50	2.50				
VARIABLE DEPTH LIFT (IN)					1.08	1.00	1.00	1.00	1.00	1.00	1.09	2.06	2.56	0.00	0.00	
183+50																
MATCH EXISTING	99.73															139.67
EXISTING ELEV					885.46	885.46	885.75	886.00	886.22	885.97	885.66	885.32	885.32	884.48	883.86	
PROPOSED ELEV					885.69	885.69	885.94	886.19	886.45	886.18	885.91	885.63	885.63	884.64	883.68	
MILLED ELEV					885.41	885.19	885.44	885.69	885.95	885.68	885.41	885.07	885.28	884.44	883.51	
MILLED DEPTH (IN)					0.50	3.24	3.72	3.60	3.27	3.57	3.06	3.00	0.50	0.50	4.22	
PAVEMENT DEPTH (IN)					3.26	6.00	6.00	6.00	6.00	6.00	6.00	6.77	4.27	2.41	2.00	
TOP LIFT (IN)					2.00	2.50	2.50	2.50	2.50	2.50	2.50	2.50	2.00	2.00	2.00	
LIFT						2.50	2.50	2.50	2.50	2.50	2.50	2.50				
VARIABLE DEPTH LIFT (IN)					1.26	1.00	1.00	1.00	1.00	1.00	1.00	1.77	2.27	0.41	0.00	
183+75																
MATCH EXISTING	120.33															132.17
EXISTING ELEV		885.04	884.97	884.97	885.47	885.47	885.75	885.98	886.20	885.95	885.66	885.35	885.35	884.58	883.94	
PROPOSED ELEV		884.47	884.97	885.10	885.68	885.68	885.94	886.19	886.45	886.17	885.90	885.63	885.63	884.78	883.93	
MILLED ELEV				884.92	885.43	885.18	885.44	885.69	885.95	885.67	885.40	885.10	885.31	884.54	883.76	
MILLED DEPTH (IN)				0.50	0.50	3.43	3.73	3.48	3.05	3.35	3.14	3.00	0.50	0.50	2.19	
PAVEMENT DEPTH (IN)				2.06	3.07	6.00	6.00	6.00	6.00	6.00	6.00	6.35	3.85	2.91	2.00	
TOP LIFT (IN)				2.00	2.00	2.50	2.50	2.50	2.50	2.50	2.50	2.50	2.00	2.00	2.00	
LIFT					2.50	2.50	2.50	2.50	2.50	2.50	2.50	2.50				
VARIABLE DEPTH LIFT (IN)				0.06	1.07	1.00	1.00	1.00	1.00	1.00	1.00	1.35	1.85	0.91	0.00	
184+00																
MATCH EXISTING	142.42															131.65
EXISTING ELEV		885.06	884.93	884.93	885.45	885.45	885.75	885.97	886.19	885.95	885.67	885.39	885.39	884.86	884.86	884.90
PROPOSED ELEV		884.43	884.93	885.05	885.68	885.68	885.94	886.19	886.44	886.17	885.90	885.63	885.63	885.08	884.95	884.45
MILLED ELEV				884.88	885.41	885.18	885.44	885.69	885.94	885.67	885.40	885.13	885.35	884.82		
MILLED DEPTH (IN)				0.53	0.50	3.23	3.72	3.42	3.00	3.29	3.24	3.11	0.50	0.50		

PAVEMENT DEPTH (IN)				2.00	3.27	6.00	6.00	6.00	6.08	6.00	6.00	6.00	3.39	3.12			
TOP LIFT (IN)				2.00	2.00	2.50	2.50	2.50	2.50	2.50	2.50	2.50	2.00	2.00			
LIFT						2.50	2.50	2.50	2.50	2.50	2.50	2.50					
VARIABLE DEPTH LIFT (IN)				0.00	1.27	1.00	1.00	1.00	1.08	1.00	1.00	1.00	1.39	1.12			

	OFFSET LEFT	110' LEFT (TURF)	SHOULDER EDGE LEFT (TURF)	SHOULDER EDGE LEFT (PAVEMENT)	75' LEFT (SHOULDER)	75' LEFT (RUNWAY)	50' LEFT	25' LEFT	CENTERLINE	25' RIGHT	50' RIGHT	75' RIGHT (RUNWAY)	75' RIGHT (SHOULDER)	SHOULDER EDGE RIGHT (PAVEMENT)	SHOULDER EDGE RIGHT (TURF)	110' RIGHT (TURF)	OFFSET RIGHT
--	-------------	------------------	---------------------------	-------------------------------	---------------------	-------------------	----------	----------	------------	-----------	-----------	--------------------	----------------------	--------------------------------	----------------------------	-------------------	--------------

184+25

MATCH EXISTING	154.63																130.11
EXISTING ELEV		884.99	885.01	885.01	885.46	885.46	885.74	885.96	886.16	885.93	885.67	885.37	885.37	884.95	884.95	884.99	
PROPOSED ELEV		884.46	884.96	885.09	885.68	885.68	885.93	886.19	886.44	886.17	885.90	885.63	885.63	885.10	884.97	884.47	
MILLED ELEV				884.92	885.42	885.18	885.43	885.69	885.91	885.67	885.40	885.12	885.12	884.91			
MILLED DEPTH (IN)				1.09	0.50	3.35	3.64	3.29	3.00	3.13	3.25	3.00	0.50	0.50			
PAVEMENT DEPTH (IN)				2.00	3.15	6.00	6.00	6.00	6.33	6.00	6.00	6.11	3.61	2.26			
TOP LIFT (IN)				2.00	2.00	2.50	2.50	2.50	2.50	2.50	2.50	2.50	2.00	2.00			
LIFT						2.50	2.50	2.50	2.50	2.50	2.50	2.50					
VARIABLE DEPTH LIFT (IN)				0.00	1.15	1.00	1.00	1.00	1.33	1.00	1.00	1.11	1.61	0.26			

	OFFSET LEFT	110' LEFT (TURF)	SHOULDER EDGE LEFT (TURF)	SHOULDER EDGE LEFT (PAVEMENT)	75' LEFT (SHOULDER)	75' LEFT (RUNWAY)	50' LEFT	25' LEFT	CENTERLINE	25' RIGHT	50' RIGHT	75' RIGHT (RUNWAY)	75' RIGHT (SHOULDER)	SHOULDER EDGE RIGHT (PAVEMENT)	SHOULDER EDGE RIGHT (TURF)	110' RIGHT (TURF)	OFFSET RIGHT
--	-------------	------------------	---------------------------	-------------------------------	---------------------	-------------------	----------	----------	------------	-----------	-----------	--------------------	----------------------	--------------------------------	----------------------------	-------------------	--------------

184+50

MATCH EXISTING	158.88																129.46
EXISTING ELEV		884.99	885.03	885.03	885.46	885.46	885.73	885.95	886.16	885.92	885.68	885.38	885.38	884.93	884.93	884.96	
PROPOSED ELEV		884.50	885.00	885.12	885.68	885.68	885.93	886.19	886.44	886.17	885.90	885.63	885.63	885.11	884.98	884.49	
MILLED ELEV				884.96	885.42	885.18	885.43	885.69	885.91	885.67	885.40	885.13	885.13	884.88			
MILLED DEPTH (IN)				0.92	0.50	3.41	3.62	3.20	3.00	3.02	3.38	3.00	0.50	0.50			
PAVEMENT DEPTH (IN)				2.00	3.09	6.00	6.00	6.00	6.31	6.00	6.00	6.00	3.50	2.70			
TOP LIFT (IN)				2.00	2.00	2.50	2.50	2.50	2.50	2.50	2.50	2.50	2.00	2.00			
LIFT						2.50	2.50	2.50	2.50	2.50	2.50	2.50					
VARIABLE DEPTH LIFT (IN)				0.00	1.09	1.00	1.00	1.00	1.31	1.00	1.00	1.00	1.50	0.70			

	OFFSET LEFT	110' LEFT (TURF)	SHOULDER EDGE LEFT (TURF)	SHOULDER EDGE LEFT (PAVEMENT)	75' LEFT (SHOULDER)	75' LEFT (RUNWAY)	50' LEFT	25' LEFT	CENTERLINE	25' RIGHT	50' RIGHT	75' RIGHT (RUNWAY)	75' RIGHT (SHOULDER)	SHOULDER EDGE RIGHT (PAVEMENT)	SHOULDER EDGE RIGHT (TURF)	110' RIGHT (TURF)	OFFSET RIGHT
--	-------------	------------------	---------------------------	-------------------------------	---------------------	-------------------	----------	----------	------------	-----------	-----------	--------------------	----------------------	--------------------------------	----------------------------	-------------------	--------------

184+75

MATCH EXISTING	161.15																128.62
EXISTING ELEV		884.97	885.02	885.02	885.47	885.47	885.72	885.94	886.15	885.91	885.68	885.40	885.40	884.98	884.98	885.00	
PROPOSED ELEV		884.52	885.02	885.15	885.67	885.67	885.93	886.18	886.44	886.17	885.90	885.63	885.63	885.12	885.00	884.50	
MILLED ELEV				884.98	885.42	885.17	885.43	885.68	885.90	885.66	885.40	885.13	885.13	884.93			
MILLED DEPTH (IN)				0.50	0.50	3.51	3.52	3.13	3.00	3.00	3.39	3.34	0.50	0.50			
PAVEMENT DEPTH (IN)				2.00	2.99	6.00	6.00	6.00	6.46	6.04	6.00	6.00	3.16	2.24			
TOP LIFT (IN)				2.00	2.00	2.50	2.50	2.50	2.50	2.50	2.50	2.50	2.00	2.00			
LIFT						2.50	2.50	2.50	2.50	2.50	2.50	2.50					
VARIABLE DEPTH LIFT (IN)				0.00	0.99	1.00	1.00	1.00	1.46	1.04	1.00	1.00	1.16	0.24			

	OFFSET LEFT	110' LEFT (TURF)	SHOULDER EDGE LEFT (TURF)	SHOULDER EDGE LEFT (PAVEMENT)	75' LEFT (SHOULDER)	75' LEFT (RUNWAY)	50' LEFT	25' LEFT	CENTERLINE	25' RIGHT	50' RIGHT	75' RIGHT (RUNWAY)	75' RIGHT (SHOULDER)	SHOULDER EDGE RIGHT (PAVEMENT)	SHOULDER EDGE RIGHT (TURF)	110' RIGHT (TURF)	OFFSET RIGHT
--	-------------	------------------	---------------------------	-------------------------------	---------------------	-------------------	----------	----------	------------	-----------	-----------	--------------------	----------------------	--------------------------------	----------------------------	-------------------	--------------

185+00

MATCH EXISTING	158.29																124.83
EXISTING ELEV		885.09	885.08	885.08	885.46	885.46	885.72	885.92	886.14	885.91	885.66	885.38	885.38	884.97	884.97	884.90	
PROPOSED ELEV		884.55	885.05	885.17	885.67	885.67	885.93	886.18	886.43	886.16	885.89	885.62	885.62	885.13	885.00	884.50	
MILLED ELEV				885.01	885.42	885.17	885.43	885.67	885.89	885.66	885.39	885.12	885.34	884.93			
MILLED DEPTH (IN)				0.87	0.50	3.46	3.56	3.00	3.00	3.00	3.24	3.09	0.50	0.50			
PAVEMENT DEPTH (IN)				2.00	3.04	6.00	6.00	6.07	6.52	6.10	6.00	6.00	3.41	2.38			
TOP LIFT (IN)				2.00	2.00	2.50	2.50	2.50	2.50	2.50	2.50	2.50	2.00	2.00			
LIFT						2.50	2.50	2.50	2.50	2.50	2.50	2.50					
VARIABLE DEPTH LIFT (IN)				0.00	1.04	1.00	1.00	1.07	1.52	1.10	1.00	1.00	1.41	0.38			

	OFFSET LEFT	110' LEFT (TURF)	SHOULDER EDGE LEFT (TURF)	SHOULDER EDGE LEFT (PAVEMENT)	75' LEFT (SHOULDER)	75' LEFT (RUNWAY)	50' LEFT	25' LEFT	CENTERLINE	25' RIGHT	50' RIGHT	75' RIGHT (RUNWAY)	75' RIGHT (SHOULDER)	SHOULDER EDGE RIGHT (PAVEMENT)	SHOULDER EDGE RIGHT (TURF)	110' RIGHT (TURF)	OFFSET RIGHT
185+25																	
MATCH EXISTING	157.14																120.03
EXISTING ELEV		885.17	885.09	885.09	885.45	885.45	885.71	885.90	886.12	885.89	885.64	885.35	885.35	884.89	884.89	884.79	
PROPOSED ELEV		884.57	885.07	885.20	885.67	885.67	885.92	886.18	886.43	886.16	885.89	885.62	885.62	885.13	885.00	884.50	
MILLED ELEV				885.03	885.41	885.17	885.42	885.65	885.87	885.64	885.39	885.10	885.31	884.85			
MILLED DEPTH (IN)				0.74	0.50	3.37	3.43	3.00	3.00	3.00	3.00	3.00	0.50	0.50			
PAVEMENT DEPTH (IN)				2.00	3.13	6.00	6.00	6.28	6.69	6.29	6.01	6.28	3.78	3.33			
TOP LIFT (IN)				2.00	2.00	2.50	2.50	2.50	2.50	2.50	2.50	2.50	2.00	2.00			
LIFT						2.50	2.50	2.50	2.50	2.50	2.50	2.50					
VARIABLE DEPTH LIFT (IN)				0.00	1.13	1.00	1.00	1.28	1.69	1.29	1.01	1.28	1.78	1.33			

	OFFSET LEFT	110' LEFT (TURF)	SHOULDER EDGE LEFT (TURF)	SHOULDER EDGE LEFT (PAVEMENT)	75' LEFT (SHOULDER)	75' LEFT (RUNWAY)	50' LEFT	25' LEFT	CENTERLINE	25' RIGHT	50' RIGHT	75' RIGHT (RUNWAY)	75' RIGHT (SHOULDER)	SHOULDER EDGE RIGHT (PAVEMENT)	SHOULDER EDGE RIGHT (TURF)	110' RIGHT (TURF)	OFFSET RIGHT
185+50																	
MATCH EXISTING	184.73																113.60
EXISTING ELEV		885.22	885.11	885.11	885.43	885.43	885.69	885.89	886.11	885.87	885.64	885.37	885.37	884.94	884.94	884.69	
PROPOSED ELEV		884.58	885.08	885.21	885.67	885.67	885.92	886.18	886.43	886.16	885.89	885.62	885.62	885.13	885.00	884.50	
MILLED ELEV				885.04	885.39	885.17	885.42	885.64	885.86	885.62	885.39	885.12	885.33	884.89			
MILLED DEPTH (IN)				0.76	0.50	3.17	3.17	3.00	3.00	3.00	3.00	3.05	0.50	0.50			
PAVEMENT DEPTH (IN)				2.00	3.33	6.00	6.00	6.47	6.79	6.49	6.03	6.00	3.45	2.81			
TOP LIFT (IN)				2.00	2.00	2.50	2.50	2.50	2.50	2.50	2.50	2.50	2.00	2.00			
LIFT						2.50	2.50	2.50	2.50	2.50	2.50	2.50					
VARIABLE DEPTH LIFT (IN)				0.00	1.33	1.00	1.00	1.47	1.79	1.49	1.03	1.00	1.45	0.81			

	OFFSET LEFT	110' LEFT (TURF)	SHOULDER EDGE LEFT (TURF)	SHOULDER EDGE LEFT (PAVEMENT)	75' LEFT (SHOULDER)	75' LEFT (RUNWAY)	50' LEFT	25' LEFT	CENTERLINE	25' RIGHT	50' RIGHT	75' RIGHT (RUNWAY)	75' RIGHT (SHOULDER)	SHOULDER EDGE RIGHT (PAVEMENT)	SHOULDER EDGE RIGHT (TURF)	110' RIGHT (TURF)	OFFSET RIGHT
185+75																	
MATCH EXISTING	187.67																112.18
EXISTING ELEV		885.21	885.12	885.12	885.41	885.41	885.66	885.87	886.09	885.85	885.63	885.36	885.36	884.91	884.91	884.65	
PROPOSED ELEV		884.58	885.08	885.21	885.67	885.67	885.92	886.17	886.43	886.16	885.89	885.62	885.62	885.14	885.01	884.51	
MILLED ELEV				885.04	885.36	885.16	885.41	885.62	885.84	885.60	885.38	885.11	885.31	884.87			
MILLED DEPTH (IN)				0.98	0.50	3.00	3.00	3.00	3.00	3.00	3.00	3.00	0.50	0.50			
PAVEMENT DEPTH (IN)				2.00	3.62	6.12	6.07	6.60	7.05	6.63	6.10	6.17	3.67	3.22			
TOP LIFT (IN)				2.00	2.00	2.50	2.50	2.50	2.50	2.50	2.50	2.50	2.00	2.00			
LIFT						2.50	2.50	2.50	2.50	2.50	2.50	2.50					
VARIABLE DEPTH LIFT (IN)				0.00	1.62	1.12	1.07	1.60	2.05	1.63	1.10	1.17	1.67	1.22			

	OFFSET LEFT	110' LEFT (TURF)	SHOULDER EDGE LEFT (TURF)	SHOULDER EDGE LEFT (PAVEMENT)	75' LEFT (SHOULDER)	75' LEFT (RUNWAY)	50' LEFT	25' LEFT	CENTERLINE	25' RIGHT	50' RIGHT	75' RIGHT (RUNWAY)	75' RIGHT (SHOULDER)	SHOULDER EDGE RIGHT (PAVEMENT)	SHOULDER EDGE RIGHT (TURF)	110' RIGHT (TURF)	OFFSET RIGHT
186+00																	
MATCH EXISTING	183.72																114.16
EXISTING ELEV		885.16	885.10	885.10	885.42	885.42	885.66	885.87	886.09	885.85	885.62	885.33	885.33	884.90	884.90	884.78	
PROPOSED ELEV		884.58	885.08	885.21	885.66	885.66	885.92	886.17	886.42	886.16	885.89	885.62	885.62	885.15	885.03	884.53	
MILLED ELEV				885.04	885.38	885.16	885.41	885.62	885.84	885.60	885.37	885.08	885.29	884.86			
MILLED DEPTH (IN)				0.74	0.50	3.09	3.00	3.00	3.00	3.00	3.00	3.00	0.50	0.50			
PAVEMENT DEPTH (IN)				2.00	3.41	6.00	6.02	6.60	7.04	6.70	6.21	6.40	3.90	3.50			
TOP LIFT (IN)				2.00	2.00	2.50	2.50	2.50	2.50	2.50	2.50	2.50	2.00	2.00			
LIFT						2.50	2.50	2.50	2.50	2.50	2.50	2.50					
VARIABLE DEPTH LIFT (IN)				0.00	1.41	1.00	1.02	1.60	2.04	1.70	1.21	1.40	1.90	1.50			
186+25																	
MATCH EXISTING	169.59																153.59
EXISTING ELEV		885.09	885.08	885.08	885.41	885.41	885.66	885.86	886.07	885.84	885.60	885.30	885.30	884.93	884.93	884.49	
PROPOSED ELEV		884.58	885.08	885.21	885.66	885.66	885.91	886.17	886.42	886.15	885.88	885.62	885.62	885.16	885.04	884.54	
MILLED ELEV				885.04	885.37	885.16	885.41	885.61	885.82	885.59	885.35	885.05	885.26	884.89			
MILLED DEPTH (IN)				0.52	0.50	3.01	3.00	3.00	3.00	3.00	3.00	3.00	0.50	0.50			
PAVEMENT DEPTH (IN)				2.00	3.49	6.00	6.05	6.69	7.19	6.78	6.38	6.79	4.29	3.22			
TOP LIFT (IN)				2.00	2.00	2.50	2.50	2.50	2.50	2.50	2.50	2.50	2.00	2.00			
LIFT						2.50	2.50	2.50	2.50	2.50	2.50	2.50					
VARIABLE DEPTH LIFT (IN)				0.00	1.49	1.00	1.05	1.69	2.19	1.78	1.38	1.79	2.29	1.22			
186+50																	
MATCH EXISTING	163.06																123.90
EXISTING ELEV		884.98	885.00	885.00	885.41	885.41	885.65	885.86	886.07	885.83	885.59	885.29	885.29	884.91	884.91	884.52	
PROPOSED ELEV		884.58	885.08	885.20	885.66	885.66	885.91	886.17	886.42	886.15	885.88	885.62	885.62	885.16	885.04	884.54	
MILLED ELEV				884.96	885.37	885.16	885.40	885.61	885.82	885.58	885.34	885.04	885.25	884.86			
MILLED DEPTH (IN)				0.50	0.50	3.04	3.00	3.00	3.00	3.00	3.00	3.00	0.50	0.50			
PAVEMENT DEPTH (IN)				2.95	3.46	6.00	6.16	6.72	7.22	6.91	6.53	6.86	4.36	3.58			
TOP LIFT (IN)				2.00	2.00	2.50	2.50	2.50	2.50	2.50	2.50	2.50	2.00	2.00			
LIFT						2.50	2.50	2.50	2.50	2.50	2.50	2.50					
VARIABLE DEPTH LIFT (IN)				0.95	1.46	1.00	1.16	1.72	2.22	1.91	1.53	1.86	2.36	1.58			
186+75																	
MATCH EXISTING	156.03																114.88
EXISTING ELEV		884.73	884.99	884.99	885.38	885.38	885.63	885.83	886.05	885.81	885.58	885.28	885.28	884.85	884.85	884.62	
PROPOSED ELEV		884.58	885.08	885.20	885.66	885.66	885.91	886.16	886.42	886.15	885.88	885.61	885.61	885.16	885.04	884.54	
MILLED ELEV				884.95	885.33	885.13	885.38	885.58	885.80	885.56	885.33	885.03	885.24	884.80			
MILLED DEPTH (IN)				0.50	0.50	3.00	3.00	3.00	3.00	3.00	3.00	3.00	0.50	0.50			

PAVEMENT DEPTH (IN)				3.06	3.85	6.35	6.40	6.99	7.42	7.02	6.65	6.95	4.45	4.26			
TOP LIFT (IN)				2.00	2.00	2.50	2.50	2.50	2.50	2.50	2.50	2.50	2.00	2.00			
LIFT						2.50	2.50	2.50	2.50	2.50	2.50	2.50					
VARIABLE DEPTH LIFT (IN)				1.06	1.85	1.35	1.40	1.99	2.42	2.02	1.65	1.95	2.45	2.26			
	OFFSET LEFT	110' LEFT (TURF)	SHOULDER EDGE LEFT (TURF)	SHOULDER EDGE LEFT (PAVEMENT)	75' LEFT (SHOULDER)	75' LEFT (RUNWAY)	50' LEFT	25' LEFT	CENTERLINE	25' RIGHT	50' RIGHT	75' RIGHT (RUNWAY)	75' RIGHT (SHOULDER)	SHOULDER EDGE RIGHT (PAVEMENT)	SHOULDER EDGE RIGHT (TURF)	110' RIGHT (TURF)	OFFSET RIGHT
187+00																	
MATCH EXISTING	135.08																123.57
EXISTING ELEV		884.90	884.98	884.98	885.35	885.35	885.61	885.81	886.02	885.80	885.56	885.31	885.31	884.84	884.84	884.85	
PROPOSED ELEV		884.57	885.07	885.20	885.65	885.65	885.91	886.16	886.41	886.15	885.88	885.61	885.61	885.16	885.03	884.53	
MILLED ELEV				884.94	885.31	885.10	885.36	885.56	885.77	885.55	885.31	885.06	885.27	884.80			
MILLED DEPTH (IN)				0.50	0.50	3.00	3.00	3.00	3.00	3.00	3.00	3.00	0.50	0.50			
PAVEMENT DEPTH (IN)				3.16	4.16	6.66	6.60	7.16	7.70	7.11	6.80	6.63	4.13	4.28			
TOP LIFT (IN)				2.00	2.00	2.50	2.50	2.50	2.50	2.50	2.50	2.50	2.00	2.00			
LIFT						2.50	2.50	2.50	2.50	2.50	2.50	2.50					
VARIABLE DEPTH LIFT (IN)				1.16	2.16	1.66	1.60	2.16	2.70	2.11	1.80	1.63	2.13	2.28			
	OFFSET LEFT	110' LEFT (TURF)	SHOULDER EDGE LEFT (TURF)	SHOULDER EDGE LEFT (PAVEMENT)	75' LEFT (SHOULDER)	75' LEFT (RUNWAY)	50' LEFT	25' LEFT	CENTERLINE	25' RIGHT	50' RIGHT	75' RIGHT (RUNWAY)	75' RIGHT (SHOULDER)	SHOULDER EDGE RIGHT (PAVEMENT)	SHOULDER EDGE RIGHT (TURF)	110' RIGHT (TURF)	OFFSET RIGHT
187+25																	
MATCH EXISTING	133.15																123.34
EXISTING ELEV		884.83	884.98	884.98	885.32	885.32	885.59	885.80	886.01	885.78	885.54	885.27	885.27	884.85	884.85	884.96	
PROPOSED ELEV		884.57	885.07	885.20	885.65	885.65	885.90	886.16	886.41	886.14	885.88	885.61	885.61	885.16	885.03	884.53	
MILLED ELEV				884.94	885.28	885.07	885.34	885.55	885.76	885.53	885.29	885.02	885.23	884.80			
MILLED DEPTH (IN)				0.50	0.50	3.00	3.00	3.00	3.00	3.00	3.00	3.00	0.50	0.50			
PAVEMENT DEPTH (IN)				3.06	4.42	6.92	6.74	7.25	7.85	7.39	7.10	7.10	4.60	4.23			
TOP LIFT (IN)				2.00	2.00	2.50	2.50	2.50	2.50	2.50	2.50	2.50	2.00	2.00			
LIFT						2.50	2.50	2.50	2.50	2.50	2.50	2.50					
VARIABLE DEPTH LIFT (IN)				1.06	2.42	1.92	1.74	2.25	2.85	2.39	2.10	2.10	2.60	2.23			
	OFFSET LEFT	110' LEFT (TURF)	SHOULDER EDGE LEFT (TURF)	SHOULDER EDGE LEFT (PAVEMENT)	75' LEFT (SHOULDER)	75' LEFT (RUNWAY)	50' LEFT	25' LEFT	CENTERLINE	25' RIGHT	50' RIGHT	75' RIGHT (RUNWAY)	75' RIGHT (SHOULDER)	SHOULDER EDGE RIGHT (PAVEMENT)	SHOULDER EDGE RIGHT (TURF)	110' RIGHT (TURF)	OFFSET RIGHT
187+50																	
MATCH EXISTING	138.10																121.17
EXISTING ELEV		884.87	884.99	884.99	885.33	885.33	885.61	885.81	886.01	885.79	885.54	885.29	885.29	884.92	884.92	885.01	
PROPOSED ELEV		884.57	885.07	885.19	885.65	885.65	885.90	886.16	886.41	886.14	885.88	885.61	885.61	885.16	885.04	884.54	
MILLED ELEV				884.95	885.29	885.08	885.36	885.56	885.76	885.54	885.29	885.04	885.25	884.88			
MILLED DEPTH (IN)				0.50	0.50	3.00	3.00	3.00	3.00	3.00	3.00	3.00	0.50	0.50			
PAVEMENT DEPTH (IN)				2.97	4.36	6.86	6.55	7.14	7.74	7.28	6.98	6.86	4.36	3.38			
TOP LIFT (IN)				2.00	2.00	2.50	2.50	2.50	2.50	2.50	2.50	2.50	2.00	2.00			
LIFT						2.50	2.50	2.50	2.50	2.50	2.50	2.50					
VARIABLE DEPTH LIFT (IN)				0.97	2.36	1.86	1.55	2.14	2.74	2.28	1.98	1.86	2.36	1.38			
	OFFSET LEFT	110' LEFT (TURF)	SHOULDER EDGE LEFT (TURF)	SHOULDER EDGE LEFT (PAVEMENT)	75' LEFT (SHOULDER)	75' LEFT (RUNWAY)	50' LEFT	25' LEFT	CENTERLINE	25' RIGHT	50' RIGHT	75' RIGHT (RUNWAY)	75' RIGHT (SHOULDER)	SHOULDER EDGE RIGHT (PAVEMENT)	SHOULDER EDGE RIGHT (TURF)	110' RIGHT (TURF)	OFFSET RIGHT
187+75																	

MATCH EXISTING	136.12																123.52
EXISTING ELEV		884.84	884.96	884.96	885.35	885.35	885.63	885.83	886.02	885.80	885.56	885.29	885.29	884.85	884.85	884.94	
PROPOSED ELEV		884.57	885.07	885.19	885.65	885.65	885.90	886.15	886.41	886.14	885.87	885.61	885.61	885.17	885.04	884.54	
MILLED ELEV				884.92	885.31	885.10	885.38	885.58	885.77	885.55	885.31	885.04	885.25	884.81			
MILLED DEPTH (IN)				0.50	0.50	3.00	3.00	3.00	3.00	3.00	3.00	3.00	0.50	0.50			
PAVEMENT DEPTH (IN)				3.25	4.08	6.58	6.24	6.83	7.60	7.08	6.79	6.79	4.29	4.28			
TOP LIFT (IN)				2.00	2.00	2.50	2.50	2.50	2.50	2.50	2.50	2.50	2.00	2.00			
LIFT						2.50	2.50	2.50	2.50	2.50	2.50	2.50					
VARIABLE DEPTH LIFT (IN)				1.25	2.08	1.58	1.24	1.83	2.60	2.08	1.79	1.79	2.29	2.28			

	OFFSET LEFT	110' LEFT (TURF)	SHOULDER EDGE LEFT (TURF)	SHOULDER EDGE LEFT (PAVEMENT)	75' LEFT (SHOULDER)	75' LEFT (RUNWAY)	50' LEFT	25' LEFT	CENTERLINE	25' RIGHT	50' RIGHT	75' RIGHT (RUNWAY)	75' RIGHT (SHOULDER)	SHOULDER EDGE RIGHT (PAVEMENT)	SHOULDER EDGE RIGHT (TURF)	110' RIGHT (TURF)	OFFSET RIGHT
188+00																	
MATCH EXISTING	136.69																118.73
EXISTING ELEV		884.91	884.96	884.96	885.41	885.41	885.66	885.85	886.02	885.82	885.58	885.33	885.33	884.86	884.86	884.83	
PROPOSED ELEV		884.56	885.06	885.19	885.64	885.64	885.90	886.15	886.40	886.14	885.87	885.61	885.61	885.17	885.05	884.55	
MILLED ELEV				884.92	885.37	885.14	885.40	885.60	885.77	885.57	885.33	885.08	885.29	884.82			
MILLED DEPTH (IN)				0.50	0.50	3.15	3.09	3.00	3.00	3.00	3.00	3.00	0.50	0.50			
PAVEMENT DEPTH (IN)				3.21	3.35	6.00	6.00	6.56	7.57	6.84	6.45	6.30	3.80	4.21			
TOP LIFT (IN)				2.00	2.00	2.50	2.50	2.50	2.50	2.50	2.50	2.50	2.00	2.00			
LIFT						2.50	2.50	2.50	2.50	2.50	2.50	2.50					
VARIABLE DEPTH LIFT (IN)				1.21	1.35	1.00	1.00	1.56	2.57	1.84	1.45	1.30	1.80	2.21			

	OFFSET LEFT	110' LEFT (TURF)	SHOULDER EDGE LEFT (TURF)	SHOULDER EDGE LEFT (PAVEMENT)	75' LEFT (SHOULDER)	75' LEFT (RUNWAY)	50' LEFT	25' LEFT	CENTERLINE	25' RIGHT	50' RIGHT	75' RIGHT (RUNWAY)	75' RIGHT (SHOULDER)	SHOULDER EDGE RIGHT (PAVEMENT)	SHOULDER EDGE RIGHT (TURF)	110' RIGHT (TURF)	OFFSET RIGHT
188+25																	
MATCH EXISTING	138.11																114.59
EXISTING ELEV		884.99	885.00	885.00	885.41	885.41	885.66	885.86	886.05	885.83	885.59	885.33	885.33	884.84	884.84	884.73	
PROPOSED ELEV		884.56	885.06	885.19	885.64	885.64	885.90	886.15	886.40	886.14	885.87	885.60	885.60	885.18	885.05	884.55	
MILLED ELEV				884.96	885.37	885.14	885.40	885.61	885.80	885.58	885.34	885.08	885.29	884.80			
MILLED DEPTH (IN)				0.50	0.50	3.24	3.21	3.00	3.00	3.00	3.00	3.00	0.50	0.50			
PAVEMENT DEPTH (IN)				2.71	3.26	6.00	6.00	6.47	7.21	6.71	6.30	6.24	3.74	4.57			
TOP LIFT (IN)				2.00	2.00	2.50	2.50	2.50	2.50	2.50	2.50	2.50	2.00	2.00			
LIFT						2.50	2.50	2.50	2.50	2.50	2.50	2.50					
VARIABLE DEPTH LIFT (IN)				0.71	1.26	1.00	1.00	1.47	2.21	1.71	1.30	1.24	1.74	2.57			

	OFFSET LEFT	110' LEFT (TURF)	SHOULDER EDGE LEFT (TURF)	SHOULDER EDGE LEFT (PAVEMENT)	75' LEFT (SHOULDER)	75' LEFT (RUNWAY)	50' LEFT	25' LEFT	CENTERLINE	25' RIGHT	50' RIGHT	75' RIGHT (RUNWAY)	75' RIGHT (SHOULDER)	SHOULDER EDGE RIGHT (PAVEMENT)	SHOULDER EDGE RIGHT (TURF)	110' RIGHT (TURF)	OFFSET RIGHT
188+50																	
MATCH EXISTING	140.33																114.02
EXISTING ELEV		884.99	885.02	885.02	885.40	885.40	885.66	885.86	886.07	885.84	885.60	885.35	885.35	884.87	884.87	884.76	
PROPOSED ELEV		884.56	885.06	885.18	885.64	885.64	885.89	886.15	886.40	886.13	885.87	885.60	885.60	885.18	885.06	884.56	
MILLED ELEV				884.97	885.36	885.14	885.39	885.61	885.82	885.59	885.35	885.10	885.31	884.83			
MILLED DEPTH (IN)				0.50	0.50	3.18	3.18	3.00	3.00	3.00	3.00	3.00	0.50	0.50			
PAVEMENT DEPTH (IN)				2.52	3.32	6.00	6.00	6.38	6.94	6.56	6.24	6.07	3.57	4.19			
TOP LIFT (IN)				2.00	2.00	2.50	2.50	2.50	2.50	2.50	2.50	2.50	2.00	2.00			
LIFT						2.50	2.50	2.50	2.50	2.50	2.50	2.50					
VARIABLE DEPTH LIFT (IN)				0.52	1.32	1.00	1.00	1.38	1.94	1.56	1.24	1.07	1.57	2.19			

	OFFSET LEFT	110' LEFT (TURF)	SHOULDER EDGE LEFT (TURF)	SHOULDER EDGE LEFT (PAVEMENT)	75' LEFT (SHOULDER)	75' LEFT (RUNWAY)	50' LEFT	25' LEFT	CENTERLINE	25' RIGHT	50' RIGHT	75' RIGHT (RUNWAY)	75' RIGHT (SHOULDER)	SHOULDER EDGE RIGHT (PAVEMENT)	SHOULDER EDGE RIGHT (TURF)	110' RIGHT (TURF)	OFFSET RIGHT
188+75																	
MATCH EXISTING	142.22																114.59
EXISTING ELEV		884.99	885.00	885.00	885.41	885.41	885.66	885.87	886.08	885.85	885.61	885.34	885.34	884.91	884.91	884.85	
PROPOSED ELEV		884.56	885.06	885.18	885.64	885.64	885.89	886.14	886.40	886.13	885.87	885.60	885.60	885.19	885.06	884.56	
MILLED ELEV				884.96	885.37	885.14	885.39	885.62	885.83	885.60	885.36	885.09	885.30	884.86			
MILLED DEPTH (IN)				0.50	0.50	3.23	3.24	3.00	3.00	3.00	3.00	3.00	0.50	0.50			
PAVEMENT DEPTH (IN)				2.69	3.27	6.00	6.00	6.25	6.84	6.39	6.03	6.17	3.67	3.87			
TOP LIFT (IN)				2.00	2.00	2.50	2.50	2.50	2.50	2.50	2.50	2.50	2.00	2.00			
LIFT						2.50	2.50	2.50	2.50	2.50	2.50	2.50					
VARIABLE DEPTH LIFT (IN)				0.69	1.27	1.00	1.00	1.25	1.84	1.39	1.03	1.17	1.67	1.87			
189+00																	
MATCH EXISTING	144.73																115.94
EXISTING ELEV		884.98	885.02	885.02	885.43	885.43	885.68	885.88	886.09	885.87	885.64	885.39	885.39	884.92	884.92	884.91	
PROPOSED ELEV		884.55	885.05	885.18	885.64	885.64	885.89	886.14	886.39	886.13	885.86	885.60	885.60	885.19	885.07	884.57	
MILLED ELEV				884.98	885.39	885.14	885.39	885.63	885.84	885.62	885.36	885.10	885.35	884.88			
MILLED DEPTH (IN)				0.50	0.50	3.57	3.45	3.00	3.00	3.00	3.35	3.49	0.50	0.50			
PAVEMENT DEPTH (IN)				2.37	2.93	6.00	6.00	6.14	6.68	6.09	6.00	6.00	3.01	3.76			
TOP LIFT (IN)				2.00	2.00	2.50	2.50	2.50	2.50	2.50	2.50	2.50	2.00	2.00			
LIFT						2.50	2.50	2.50	2.50	2.50	2.50	2.50					
VARIABLE DEPTH LIFT (IN)				0.37	0.93	1.00	1.00	1.14	1.68	1.09	1.00	1.00	1.01	1.76			
189+25																	
MATCH EXISTING	150.28																116.70
EXISTING ELEV		884.93	885.01	885.01	885.42	885.42	885.68	885.89	886.10	885.89	885.67	885.37	885.37	885.01	885.01	885.02	
PROPOSED ELEV		884.55	885.05	885.18	885.63	885.63	885.89	886.14	886.39	886.13	885.86	885.60	885.60	885.20	885.07	884.57	
MILLED ELEV				884.96	885.37	885.13	885.39	885.64	885.85	885.63	885.36	885.10	885.33	884.97			
MILLED DEPTH (IN)				0.50	0.50	3.39	3.47	3.00	3.00	3.12	3.67	3.23	0.50	0.50			
PAVEMENT DEPTH (IN)				2.58	3.11	6.00	6.00	6.03	6.53	6.00	6.00	6.00	3.27	2.74			
TOP LIFT (IN)				2.00	2.00	2.50	2.50	2.50	2.50	2.50	2.50	2.50	2.00	2.00			
LIFT						2.50	2.50	2.50	2.50	2.50	2.50	2.50					
VARIABLE DEPTH LIFT (IN)				0.58	1.11	1.00	1.00	1.03	1.53	1.00	1.00	1.00	1.27	0.74			
189+50																	
MATCH EXISTING	138.37																115.68
EXISTING ELEV		884.89	885.01	885.01	885.43	885.43	885.68	885.89	886.10	885.90	885.69	885.42	885.42	885.07	885.07	885.06	
PROPOSED ELEV		884.55	885.05	885.18	885.63	885.63	885.88	886.14	886.39	886.13	885.86	885.60	885.60	885.20	885.08	884.58	
MILLED ELEV				884.97	885.38	885.13	885.38	885.64	885.85	885.63	885.36	885.10	885.38	885.02			
MILLED DEPTH (IN)				0.50	0.50	3.55	3.51	3.01	3.00	3.27	3.93	3.87	0.50	0.50			

PAVEMENT DEPTH (IN)				2.54	2.95	6.00	6.00	6.00	6.44	6.00	6.00	6.00	2.63	2.13			
TOP LIFT (IN)				2.00	2.00	2.50	2.50	2.50	2.50	2.50	2.50	2.50	2.00	2.00			
LIFT						2.50	2.50	2.50	2.50	2.50	2.50	2.50					
VARIABLE DEPTH LIFT (IN)				0.54	0.95	1.00	1.00	1.00	1.44	1.00	1.00	1.00	0.63	0.13			

	OFFSET LEFT	110' LEFT (TURF)	SHOULDER EDGE LEFT (TURF)	SHOULDER EDGE LEFT (PAVEMENT)	75' LEFT (SHOULDER)	75' LEFT (RUNWAY)	50' LEFT	25' LEFT	CENTERLINE	25' RIGHT	50' RIGHT	75' RIGHT (RUNWAY)	75' RIGHT (SHOULDER)	SHOULDER EDGE RIGHT (PAVEMENT)	SHOULDER EDGE RIGHT (TURF)	110' RIGHT (TURF)	OFFSET RIGHT
--	-------------	------------------	---------------------------	-------------------------------	---------------------	-------------------	----------	----------	------------	-----------	-----------	--------------------	----------------------	--------------------------------	----------------------------	-------------------	--------------

189+75

MATCH EXISTING	117.07																120.89
EXISTING ELEV		884.80	885.03	885.03	885.43	885.43	885.67	885.90	886.10	885.91	885.70	885.41	885.41	885.10	885.10	885.16	
PROPOSED ELEV		884.55	885.05	885.18	885.63	885.63	885.88	886.13	886.39	886.12	885.86	885.60	885.60	885.20	885.07	884.57	
MILLED ELEV				884.99	885.39	885.13	885.38	885.63	885.85	885.62	885.36	885.10	885.37	885.03			
MILLED DEPTH (IN)				0.50	0.50	3.68	3.52	3.15	3.00	3.47	4.13	3.82	0.50	0.81			
PAVEMENT DEPTH (IN)				2.31	2.82	6.00	6.00	6.00	6.39	6.00	6.00	6.00	2.68	2.00			
TOP LIFT (IN)				2.00	2.00	2.50	2.50	2.50	2.50	2.50	2.50	2.50	2.00	2.00			
LIFT						2.50	2.50	2.50	2.50	2.50	2.50	2.50					
VARIABLE DEPTH LIFT (IN)				0.31	0.82	1.00	1.00	1.00	1.39	1.00	1.00	1.00	0.68	0.00			

	OFFSET LEFT	110' LEFT (TURF)	SHOULDER EDGE LEFT (TURF)	SHOULDER EDGE LEFT (PAVEMENT)	75' LEFT (SHOULDER)	75' LEFT (RUNWAY)	50' LEFT	25' LEFT	CENTERLINE	25' RIGHT	50' RIGHT	75' RIGHT (RUNWAY)	75' RIGHT (SHOULDER)	SHOULDER EDGE RIGHT (PAVEMENT)	SHOULDER EDGE RIGHT (TURF)	110' RIGHT (TURF)	OFFSET RIGHT
--	-------------	------------------	---------------------------	-------------------------------	---------------------	-------------------	----------	----------	------------	-----------	-----------	--------------------	----------------------	--------------------------------	----------------------------	-------------------	--------------

190+00

MATCH EXISTING	115.95																121.20
EXISTING ELEV		884.95	885.09	885.09	885.46	885.46	885.69	885.91	886.12	885.93	885.72	885.45	885.45	885.05	885.05	885.00	
PROPOSED ELEV		884.55	885.05	885.18	885.63	885.63	885.88	886.13	886.38	886.12	885.86	885.59	885.59	885.19	885.07	884.57	
MILLED ELEV				885.01	885.42	885.13	885.38	885.63	885.87	885.62	885.36	885.09	885.40	885.01			
MILLED DEPTH (IN)				0.89	0.50	4.04	3.73	3.32	3.00	3.67	4.35	4.23	0.50	0.50			
PAVEMENT DEPTH (IN)				2.00	2.46	6.00	6.00	6.00	6.18	6.00	6.00	6.00	2.27	2.21			
TOP LIFT (IN)				2.00	2.00	2.50	2.50	2.50	2.50	2.50	2.50	2.50	2.00	2.00			
LIFT						2.50	2.50	2.50	2.50	2.50	2.50	2.50					
VARIABLE DEPTH LIFT (IN)				0.00	0.46	1.00	1.00	1.00	1.18	1.00	1.00	1.00	0.27	0.21			

	OFFSET LEFT	110' LEFT (TURF)	SHOULDER EDGE LEFT (TURF)	SHOULDER EDGE LEFT (PAVEMENT)	75' LEFT (SHOULDER)	75' LEFT (RUNWAY)	50' LEFT	25' LEFT	CENTERLINE	25' RIGHT	50' RIGHT	75' RIGHT (RUNWAY)	75' RIGHT (SHOULDER)	SHOULDER EDGE RIGHT (PAVEMENT)	SHOULDER EDGE RIGHT (TURF)	110' RIGHT (TURF)	OFFSET RIGHT
--	-------------	------------------	---------------------------	-------------------------------	---------------------	-------------------	----------	----------	------------	-----------	-----------	--------------------	----------------------	--------------------------------	----------------------------	-------------------	--------------

190+25

MATCH EXISTING	133.12																114.01
EXISTING ELEV		884.88	885.03	885.03	885.44	885.44	885.70	885.91	886.13	885.94	885.73	885.47	885.47	885.06	885.06	884.69	
PROPOSED ELEV		884.55	885.05	885.18	885.62	885.62	885.88	886.13	886.38	886.12	885.86	885.59	885.59	885.19	885.06	884.56	
MILLED ELEV				884.99	885.40	885.12	885.38	885.63	885.88	885.62	885.36	885.09	885.42	885.02			
MILLED DEPTH (IN)				0.50	0.50	3.85	3.91	3.35	3.02	3.84	4.52	4.47	0.50	0.50			
PAVEMENT DEPTH (IN)				2.29	2.65	6.00	6.00	6.00	6.00	6.00	6.00	6.00	2.03	2.06			
TOP LIFT (IN)				2.00	2.00	2.50	2.50	2.50	2.50	2.50	2.50	2.50	2.00	2.00			
LIFT						2.50	2.50	2.50	2.50	2.50	2.50	2.50					
VARIABLE DEPTH LIFT (IN)				0.29	0.65	1.00	1.00	1.00	1.00	1.00	1.00	1.00	0.03	0.06			

	OFFSET LEFT	110' LEFT (TURF)	SHOULDER EDGE LEFT (TURF)	SHOULDER EDGE LEFT (PAVEMENT)	75' LEFT (SHOULDER)	75' LEFT (RUNWAY)	50' LEFT	25' LEFT	CENTERLINE	25' RIGHT	50' RIGHT	75' RIGHT (RUNWAY)	75' RIGHT (SHOULDER)	SHOULDER EDGE RIGHT (PAVEMENT)	SHOULDER EDGE RIGHT (TURF)	110' RIGHT (TURF)	OFFSET RIGHT
--	-------------	------------------	---------------------------	-------------------------------	---------------------	-------------------	----------	----------	------------	-----------	-----------	--------------------	----------------------	--------------------------------	----------------------------	-------------------	--------------

190+50

MATCH EXISTING	142.26																113.51
EXISTING ELEV		884.88	885.02	885.02	885.44	885.44	885.70	885.91	886.15	885.95	885.74	885.46	885.46	885.00	885.00	884.70	
PROPOSED ELEV		884.55	885.05	885.18	885.62	885.62	885.87	886.13	886.38	886.12	885.85	885.59	885.59	885.19	885.06	884.56	
MILLED ELEV				884.98	885.40	885.12	885.37	885.63	885.88	885.62	885.35	885.09	885.41	884.95			
MILLED DEPTH (IN)				0.50	0.50	3.85	3.92	3.35	3.26	4.03	4.61	4.38	0.50	0.50			
PAVEMENT DEPTH (IN)				2.36	2.65	6.00	6.00	6.00	6.00	6.00	6.00	6.00	2.12	2.78			
TOP LIFT (IN)				2.00	2.00	2.50	2.50	2.50	2.50	2.50	2.50	2.50	2.00	2.00			
LIFT						2.50	2.50	2.50	2.50	2.50	2.50	2.50					
VARIABLE DEPTH LIFT (IN)				0.36	0.65	1.00	1.00	1.00	1.00	1.00	1.00	1.00	0.12	0.78			

	OFFSET LEFT	110' LEFT (TURF)	SHOULDER EDGE LEFT (TURF)	SHOULDER EDGE LEFT (PAVEMENT)	75' LEFT (SHOULDER)	75' LEFT (RUNWAY)	50' LEFT	25' LEFT	CENTERLINE	25' RIGHT	50' RIGHT	75' RIGHT (RUNWAY)	75' RIGHT (SHOULDER)	SHOULDER EDGE RIGHT (PAVEMENT)	SHOULDER EDGE RIGHT (TURF)	110' RIGHT (TURF)	OFFSET RIGHT
190+75																	
MATCH EXISTING	153.58																113.99
EXISTING ELEV		884.87	885.02	885.02	885.44	885.44	885.68	885.90	886.14	885.97	885.74	885.46	885.46	885.01	885.01	884.69	
PROPOSED ELEV		884.55	885.05	885.18	885.62	885.62	885.87	886.12	886.38	886.11	885.85	885.59	885.59	885.18	885.06	884.56	
MILLED ELEV				884.98	885.40	885.12	885.37	885.62	885.88	885.61	885.35	885.09	885.42	884.97			
MILLED DEPTH (IN)				0.50	0.50	3.84	3.74	3.29	3.11	4.22	4.61	4.46	0.50	0.50			
PAVEMENT DEPTH (IN)				2.31	2.66	6.00	6.00	6.00	6.00	6.00	6.00	6.00	2.04	2.54			
TOP LIFT (IN)				2.00	2.00	2.50	2.50	2.50	2.50	2.50	2.50	2.50	2.00	2.00			
LIFT						2.50	2.50	2.50	2.50	2.50	2.50	2.50					
VARIABLE DEPTH LIFT (IN)				0.31	0.66	1.00	1.00	1.00	1.00	1.00	1.00	1.00	0.04	0.54			

	OFFSET LEFT	110' LEFT (TURF)	SHOULDER EDGE LEFT (TURF)	SHOULDER EDGE LEFT (PAVEMENT)	75' LEFT (SHOULDER)	75' LEFT (RUNWAY)	50' LEFT	25' LEFT	CENTERLINE	25' RIGHT	50' RIGHT	75' RIGHT (RUNWAY)	75' RIGHT (SHOULDER)	SHOULDER EDGE RIGHT (PAVEMENT)	SHOULDER EDGE RIGHT (TURF)	110' RIGHT (TURF)	OFFSET RIGHT
191+00																	
MATCH EXISTING	170.32																121.51
EXISTING ELEV		885.05	885.05	885.05	885.42	885.42	885.69	885.92	886.15	885.96	885.72	885.45	885.45	884.96	884.96	884.87	
PROPOSED ELEV		884.55	885.05	885.18	885.62	885.62	885.87	886.12	886.37	886.11	885.85	885.59	885.59	885.18	885.06	884.56	
MILLED ELEV				885.01	885.37	885.12	885.37	885.62	885.87	885.61	885.35	885.09	885.41	884.92			
MILLED DEPTH (IN)				0.54	0.50	3.58	3.87	3.63	3.36	4.18	4.44	4.34	0.50	0.50			
PAVEMENT DEPTH (IN)				2.00	2.92	6.00	6.00	6.00	6.00	6.00	6.00	6.00	2.16	3.18			
TOP LIFT (IN)				2.00	2.00	2.50	2.50	2.50	2.50	2.50	2.50	2.50	2.00	2.00			
LIFT						2.50	2.50	2.50	2.50	2.50	2.50	2.50					
VARIABLE DEPTH LIFT (IN)				0.00	0.92	1.00	1.00	1.00	1.00	1.00	1.00	1.00	0.16	1.18			

	OFFSET LEFT	110' LEFT (TURF)	SHOULDER EDGE LEFT (TURF)	SHOULDER EDGE LEFT (PAVEMENT)	75' LEFT (SHOULDER)	75' LEFT (RUNWAY)	50' LEFT	25' LEFT	CENTERLINE	25' RIGHT	50' RIGHT	75' RIGHT (RUNWAY)	75' RIGHT (SHOULDER)	SHOULDER EDGE RIGHT (PAVEMENT)	SHOULDER EDGE RIGHT (TURF)	110' RIGHT (TURF)	OFFSET RIGHT
191+25																	
MATCH EXISTING	166.38																121.60
EXISTING ELEV		884.91	885.05	885.05	885.44	885.44	885.71	885.94	886.17	885.96	885.71	885.40	885.40	884.98	884.98	884.79	
PROPOSED ELEV		884.55	885.05	885.17	885.61	885.61	885.87	886.12	886.37	886.11	885.85	885.59	885.59	885.18	885.06	884.56	
MILLED ELEV				885.01	885.40	885.11	885.37	885.62	885.87	885.61	885.35	885.09	885.36	884.93			
MILLED DEPTH (IN)				0.50	0.50	3.94	4.06	3.87	3.54	4.19	4.37	3.75	0.50	0.50			
PAVEMENT DEPTH (IN)				2.03	2.56	6.00	6.00	6.00	6.00	6.00	6.00	6.00	2.75	2.98			
TOP LIFT (IN)				2.00	2.00	2.50	2.50	2.50	2.50	2.50	2.50	2.50	2.00	2.00			
LIFT						2.50	2.50	2.50	2.50	2.50	2.50	2.50					
VARIABLE DEPTH LIFT (IN)				0.03	0.56	1.00	1.00	1.00	1.00	1.00	1.00	1.00	0.75	0.98			

	OFFSET LEFT	110' LEFT (TURF)	SHOULDER EDGE LEFT (TURF)	SHOULDER EDGE LEFT (PAVEMENT)	75' LEFT (SHOULDER)	75' LEFT (RUNWAY)	50' LEFT	25' LEFT	CENTERLINE	25' RIGHT	50' RIGHT	75' RIGHT (RUNWAY)	75' RIGHT (SHOULDER)	SHOULDER EDGE RIGHT (PAVEMENT)	SHOULDER EDGE RIGHT (TURF)	110' RIGHT (TURF)	OFFSET RIGHT
191+50																	
MATCH EXISTING	151.46																121.89
EXISTING ELEV		884.96	885.10	885.10	885.48	885.48	885.72	885.94	886.19	885.96	885.73	885.46	885.46	885.03	885.03	884.89	
PROPOSED ELEV		884.55	885.05	885.17	885.61	885.61	885.86	886.12	886.37	886.11	885.85	885.59	885.59	885.19	885.06	884.56	
MILLED ELEV				885.01	885.44	885.11	885.36	885.62	885.87	885.61	885.35	885.09	885.42	884.98			
MILLED DEPTH (IN)				1.07	0.50	4.47	4.25	3.93	3.88	4.24	4.59	4.47	0.50	0.50			
PAVEMENT DEPTH (IN)				2.00	2.03	6.00	6.00	6.00	6.00	6.00	6.00	6.00	2.03	2.41			
TOP LIFT (IN)				2.00	2.00	2.50	2.50	2.50	2.50	2.50	2.50	2.50	2.00	2.00			
LIFT						2.50	2.50	2.50	2.50	2.50	2.50	2.50					
VARIABLE DEPTH LIFT (IN)				0.00	0.03	1.00	1.00	1.00	1.00	1.00	1.00	1.00	0.03	0.41			
191+75																	
MATCH EXISTING	150.80																122.52
EXISTING ELEV		885.07	885.08	885.08	885.48	885.48	885.73	885.95	886.20	885.97	885.74	885.47	885.47	885.08	885.08	884.98	
PROPOSED ELEV		884.55	885.05	885.17	885.61	885.61	885.86	886.11	886.37	886.11	885.84	885.58	885.58	885.19	885.06	884.56	
MILLED ELEV				885.01	885.44	885.11	885.36	885.61	885.87	885.61	885.34	885.08	885.42	885.02			
MILLED DEPTH (IN)				0.86	0.50	4.42	4.45	4.02	3.97	4.40	4.78	4.69	0.69	0.75			
PAVEMENT DEPTH (IN)				2.00	2.08	6.00	6.00	6.00	6.00	6.00	6.00	6.00	2.00	2.00			
TOP LIFT (IN)				2.00	2.00	2.50	2.50	2.50	2.50	2.50	2.50	2.50	2.00	2.00			
LIFT						2.50	2.50	2.50	2.50	2.50	2.50	2.50					
VARIABLE DEPTH LIFT (IN)				0.00	0.08	1.00	1.00	1.00	1.00	1.00	1.00	1.00	0.00	0.00			
192+00																	
MATCH EXISTING	154.86																118.13
EXISTING ELEV		885.20	885.06	885.06	885.50	885.50	885.75	885.96	886.19	885.99	885.76	885.51	885.51	885.04	885.04	885.08	
PROPOSED ELEV		884.54	885.04	885.17	885.61	885.61	885.86	886.11	886.36	886.10	885.84	885.58	885.58	885.19	885.06	884.56	
MILLED ELEV				885.00	885.44	885.11	885.36	885.61	885.86	885.60	885.34	885.08	885.42	885.00			
MILLED DEPTH (IN)				0.74	0.74	4.74	4.63	4.15	3.94	4.68	5.00	5.09	1.09	0.50			
PAVEMENT DEPTH (IN)				2.00	2.00	6.00	6.00	6.00	6.00	6.00	6.00	6.00	2.00	2.24			
TOP LIFT (IN)				2.00	2.00	2.50	2.50	2.50	2.50	2.50	2.50	2.50	2.00	2.00			
LIFT						2.50	2.50	2.50	2.50	2.50	2.50	2.50					
VARIABLE DEPTH LIFT (IN)				0.00	0.00	1.00	1.00	1.00	1.00	1.00	1.00	1.00	0.00	0.24			
192+25																	
MATCH EXISTING	156.81																115.79
EXISTING ELEV		885.23	885.02	885.02	885.50	885.50	885.75	885.97	886.20	886.00	885.77	885.49	885.49	884.97	884.97	884.82	
PROPOSED ELEV		884.54	885.04	885.17	885.61	885.61	885.86	886.11	886.36	886.10	885.84	885.58	885.58	885.18	885.06	884.56	
MILLED ELEV				884.98	885.44	885.11	885.36	885.61	885.86	885.60	885.34	885.08	885.41	884.93			
MILLED DEPTH (IN)				0.50	0.76	4.76	4.68	4.28	4.05	4.83	5.17	4.92	0.92	0.50			

PAVEMENT DEPTH (IN)				2.22	2.00	6.00	6.00	6.00	6.00	6.00	6.00	6.00	2.00	3.05			
TOP LIFT (IN)				2.00	2.00	2.50	2.50	2.50	2.50	2.50	2.50	2.50	2.00	2.00			
LIFT						2.50	2.50	2.50	2.50	2.50	2.50	2.50					
VARIABLE DEPTH LIFT (IN)				0.22	0.00	1.00	1.00	1.00	1.00	1.00	1.00	1.00	0.00	1.05			
	OFFSET LEFT	110' LEFT (TURF)	SHOULDER EDGE LEFT (TURF)	SHOULDER EDGE LEFT (PAVEMENT)	75' LEFT (SHOULDER)	75' LEFT (RUNWAY)	50' LEFT	25' LEFT	CENTERLINE	25' RIGHT	50' RIGHT	75' RIGHT (RUNWAY)	75' RIGHT (SHOULDER)	SHOULDER EDGE RIGHT (PAVEMENT)	SHOULDER EDGE RIGHT (TURF)	110' RIGHT (TURF)	OFFSET RIGHT
192+50																	
MATCH EXISTING	154.97																119.55
EXISTING ELEV		885.18	885.02	885.02	885.51	885.51	885.77	885.99	886.20	886.00	885.78	885.52	885.52	884.96	884.96	884.95	
PROPOSED ELEV		884.54	885.04	885.16	885.60	885.60	885.86	886.11	886.36	886.10	885.84	885.58	885.58	885.18	885.05	884.55	
MILLED ELEV				884.98	885.44	885.10	885.36	885.61	885.86	885.60	885.34	885.08	885.41	884.91			
MILLED DEPTH (IN)				0.50	0.88	4.88	5.02	4.60	4.13	4.85	5.24	5.26	1.26	0.50			
PAVEMENT DEPTH (IN)				2.25	2.00	6.00	6.00	6.00	6.00	6.00	6.00	6.00	2.00	3.18			
TOP LIFT (IN)				2.00	2.00	2.50	2.50	2.50	2.50	2.50	2.50	2.50	2.00	2.00			
LIFT						2.50	2.50	2.50	2.50	2.50	2.50	2.50					
VARIABLE DEPTH LIFT (IN)				0.25	0.00	1.00	1.00	1.00	1.00	1.00	1.00	1.00	0.00	1.18			
	OFFSET LEFT	110' LEFT (TURF)	SHOULDER EDGE LEFT (TURF)	SHOULDER EDGE LEFT (PAVEMENT)	75' LEFT (SHOULDER)	75' LEFT (RUNWAY)	50' LEFT	25' LEFT	CENTERLINE	25' RIGHT	50' RIGHT	75' RIGHT (RUNWAY)	75' RIGHT (SHOULDER)	SHOULDER EDGE RIGHT (PAVEMENT)	SHOULDER EDGE RIGHT (TURF)	110' RIGHT (TURF)	OFFSET RIGHT
192+75																	
MATCH EXISTING	152.15																123.89
EXISTING ELEV		885.18	885.02	885.02	885.54	885.54	885.79	885.99	886.21	885.99	885.77	885.49	885.49	884.95	884.95	884.98	
PROPOSED ELEV		884.54	885.04	885.16	885.60	885.60	885.85	886.10	886.36	886.10	885.84	885.58	885.58	885.17	885.05	884.55	
MILLED ELEV				884.97	885.43	885.10	885.35	885.60	885.86	885.60	885.34	885.08	885.41	884.91			
MILLED DEPTH (IN)				0.50	1.31	5.31	5.21	4.60	4.20	4.75	5.24	4.97	0.97	0.50			
PAVEMENT DEPTH (IN)				2.24	2.00	6.00	6.00	6.00	6.00	6.00	6.00	6.00	2.00	3.19			
TOP LIFT (IN)				2.00	2.00	2.50	2.50	2.50	2.50	2.50	2.50	2.50	2.00	2.00			
LIFT						2.50	2.50	2.50	2.50	2.50	2.50	2.50					
VARIABLE DEPTH LIFT (IN)				0.24	0.00	1.00	1.00	1.00	1.00	1.00	1.00	1.00	0.00	1.19			
	OFFSET LEFT	110' LEFT (TURF)	SHOULDER EDGE LEFT (TURF)	SHOULDER EDGE LEFT (PAVEMENT)	75' LEFT (SHOULDER)	75' LEFT (RUNWAY)	50' LEFT	25' LEFT	CENTERLINE	25' RIGHT	50' RIGHT	75' RIGHT (RUNWAY)	75' RIGHT (SHOULDER)	SHOULDER EDGE RIGHT (PAVEMENT)	SHOULDER EDGE RIGHT (TURF)	110' RIGHT (TURF)	OFFSET RIGHT
193+00																	
MATCH EXISTING	156.80																126.98
EXISTING ELEV		885.14	885.07	885.07	885.55	885.55	885.80	885.99	886.22	885.99	885.79	885.53	885.53	884.95	884.95	885.16	
PROPOSED ELEV		884.53	885.03	885.16	885.60	885.60	885.85	886.10	886.35	886.09	885.84	885.58	885.58	885.17	885.04	884.54	
MILLED ELEV				884.99	885.43	885.10	885.35	885.60	885.85	885.59	885.34	885.08	885.41	884.91			
MILLED DEPTH (IN)				0.92	1.37	5.37	5.41	4.69	4.41	4.80	5.43	5.46	1.46	0.50			
PAVEMENT DEPTH (IN)				2.00	2.00	6.00	6.00	6.00	6.00	6.00	6.00	6.00	2.00	3.05			
TOP LIFT (IN)				2.00	2.00	2.50	2.50	2.50	2.50	2.50	2.50	2.50	2.00	2.00			
LIFT						2.50	2.50	2.50	2.50	2.50	2.50	2.50					
VARIABLE DEPTH LIFT (IN)				0.00	0.00	1.00	1.00	1.00	1.00	1.00	1.00	1.00	0.00	1.05			
	OFFSET LEFT	110' LEFT (TURF)	SHOULDER EDGE LEFT (TURF)	SHOULDER EDGE LEFT (PAVEMENT)	75' LEFT (SHOULDER)	75' LEFT (RUNWAY)	50' LEFT	25' LEFT	CENTERLINE	25' RIGHT	50' RIGHT	75' RIGHT (RUNWAY)	75' RIGHT (SHOULDER)	SHOULDER EDGE RIGHT (PAVEMENT)	SHOULDER EDGE RIGHT (TURF)	110' RIGHT (TURF)	OFFSET RIGHT
193+25																	

MATCH EXISTING	154.88																128.15
EXISTING ELEV		885.10	885.05	885.05	885.54	885.54	885.81	886.02	886.23	886.02	885.79	885.50	885.50	884.98	884.98	885.01	
PROPOSED ELEV		884.53	885.03	885.16	885.60	885.60	885.85	886.10	886.35	886.09	885.83	885.57	885.57	885.16	885.03	884.54	
MILLED ELEV				884.99	885.43	885.10	885.35	885.60	885.85	885.59	885.33	885.07	885.41	884.94			
MILLED DEPTH (IN)				0.70	1.29	5.29	5.57	5.01	4.59	5.09	5.51	5.16	1.16	0.50			
PAVEMENT DEPTH (IN)				2.00	2.00	6.00	6.00	6.00	6.00	6.00	6.00	6.00	2.00	2.62			
TOP LIFT (IN)				2.00	2.00	2.50	2.50	2.50	2.50	2.50	2.50	2.50	2.00	2.00			
LIFT						2.50	2.50	2.50	2.50	2.50	2.50	2.50					
VARIABLE DEPTH LIFT (IN)				0.00	0.00	1.00	1.00	1.00	1.00	1.00	1.00	1.00	0.00	0.62			

	OFFSET LEFT	110' LEFT (TURF)	SHOULDER EDGE LEFT (TURF)	SHOULDER EDGE LEFT (PAVEMENT)	75' LEFT (SHOULDER)	75' LEFT (RUNWAY)	50' LEFT	25' LEFT	CENTERLINE	25' RIGHT	50' RIGHT	75' RIGHT (RUNWAY)	75' RIGHT (SHOULDER)	SHOULDER EDGE RIGHT (PAVEMENT)	SHOULDER EDGE RIGHT (TURF)	110' RIGHT	OFFSET RIGHT
193+50																	
MATCH EXISTING	155.05																135.21
EXISTING ELEV		885.10	885.05	885.05	885.54	885.54	885.82	886.04	886.26	886.03	885.80	885.53	885.53	884.98	884.98	884.92	
PROPOSED ELEV		884.53	885.03	885.16	885.59	885.59	885.85	886.10	886.35	886.09	885.83	885.57	885.57	885.16	885.03	884.53	
MILLED ELEV				884.99	885.43	885.09	885.35	885.60	885.85	885.59	885.33	885.07	885.41	884.94			
MILLED DEPTH (IN)				0.71	1.33	5.33	5.66	5.25	4.91	5.28	5.64	5.47	1.47	0.50			
PAVEMENT DEPTH (IN)				2.00	2.00	6.00	6.00	6.00	6.00	6.00	6.00	6.00	2.00	2.55			
TOP LIFT (IN)				2.00	2.00	2.50	2.50	2.50	2.50	2.50	2.50	2.50	2.00	2.00			
LIFT						2.50	2.50	2.50	2.50	2.50	2.50	2.50					
VARIABLE DEPTH LIFT (IN)				0.00	0.00	1.00	1.00	1.00	1.00	1.00	1.00	1.00	0.00	0.55			

	OFFSET LEFT	110' LEFT (TURF)	SHOULDER EDGE LEFT (TURF)	SHOULDER EDGE LEFT (PAVEMENT)	75' LEFT (SHOULDER)	75' LEFT (RUNWAY)	50' LEFT	25' LEFT	CENTERLINE	25' RIGHT	50' RIGHT	75' RIGHT (RUNWAY)	75' RIGHT (SHOULDER)	SHOULDER EDGE RIGHT (PAVEMENT)	SHOULDER EDGE RIGHT (TURF)	110' RIGHT (TURF)	OFFSET RIGHT
193+75																	
MATCH EXISTING	147.92																136.81
EXISTING ELEV		885.14	885.09	885.09	885.54	885.54	885.82	886.03	886.23	886.02	885.80	885.53	885.53	884.96	884.96	885.01	
PROPOSED ELEV		884.53	885.03	885.15	885.59	885.59	885.84	886.10	886.35	886.09	885.83	885.57	885.57	885.15	885.02	884.52	
MILLED ELEV				884.99	885.42	885.09	885.34	885.60	885.85	885.59	885.33	885.07	885.41	884.92			
MILLED DEPTH (IN)				1.26	1.34	5.34	5.68	5.24	4.64	5.22	5.63	5.56	1.56	0.50			
PAVEMENT DEPTH (IN)				2.00	2.00	6.00	6.00	6.00	6.00	6.00	6.00	6.00	2.00	2.79			
TOP LIFT (IN)				2.00	2.00	2.50	2.50	2.50	2.50	2.50	2.50	2.50	2.00	2.00			
LIFT						2.50	2.50	2.50	2.50	2.50	2.50	2.50					
VARIABLE DEPTH LIFT (IN)				0.00	0.00	1.00	1.00	1.00	1.00	1.00	1.00	1.00	0.00	0.79			

	OFFSET LEFT	110' LEFT (TURF)	SHOULDER EDGE LEFT (TURF)	SHOULDER EDGE LEFT (PAVEMENT)	75' LEFT (SHOULDER)	75' LEFT (RUNWAY)	50' LEFT	25' LEFT	CENTERLINE	25' RIGHT	50' RIGHT	75' RIGHT (RUNWAY)	75' RIGHT (SHOULDER)	SHOULDER EDGE RIGHT (PAVEMENT)	SHOULDER EDGE RIGHT (TURF)	110' RIGHT (TURF)	OFFSET RIGHT
194+00																	
MATCH EXISTING	149.64																132.69
EXISTING ELEV		885.14	885.01	885.01	885.56	885.56	885.82	886.02	886.24	886.01	885.80	885.51	885.51	884.94	884.94	885.10	
PROPOSED ELEV		884.53	885.03	885.15	885.59	885.59	885.84	886.09	886.34	886.09	885.83	885.57	885.57	885.14	885.02	884.52	
MILLED ELEV				884.96	885.42	885.09	885.34	885.59	885.84	885.59	885.33	885.07	885.40	884.90			
MILLED DEPTH (IN)				0.50	1.66	5.66	5.71	5.17	4.73	5.13	5.66	5.32	1.32	0.50			
PAVEMENT DEPTH (IN)				2.25	2.00	6.00	6.00	6.00	6.00	6.00	6.00	6.00	2.00	2.92			
TOP LIFT (IN)				2.00	2.00	2.50	2.50	2.50	2.50	2.50	2.50	2.50	2.00	2.00			
LIFT						2.50	2.50	2.50	2.50	2.50	2.50	2.50					
VARIABLE DEPTH LIFT (IN)				0.25	0.00	1.00	1.00	1.00	1.00	1.00	1.00	1.00	0.00	0.92			

	OFFSET LEFT	110' LEFT (TURF)	SHOULDER EDGE LEFT (TURF)	SHOULDER EDGE LEFT (PAVEMENT)	75' LEFT (SHOULDER)	75' LEFT (RUNWAY)	50' LEFT	25' LEFT	CENTERLINE	25' RIGHT	50' RIGHT	75' RIGHT (RUNWAY)	75' RIGHT (SHOULDER)	SHOULDER EDGE RIGHT (PAVEMENT)	SHOULDER EDGE RIGHT (TURF)	110' RIGHT (TURF)	OFFSET RIGHT
194+25																	
MATCH EXISTING	151.57																125.37
EXISTING ELEV		885.13	885.02	885.02	885.54	885.54	885.81	886.01	886.23	886.03	885.81	885.55	885.55	884.97	884.97	885.02	
PROPOSED ELEV		884.53	885.03	885.15	885.59	885.59	885.84	886.09	886.34	886.08	885.83	885.57	885.57	885.14	885.01	884.51	
MILLED ELEV				884.98	885.42	885.09	885.34	885.59	885.84	885.58	885.33	885.07	885.40	884.93			
MILLED DEPTH (IN)				0.50	1.43	5.43	5.62	5.07	4.67	5.30	5.82	5.74	1.74	0.50			
PAVEMENT DEPTH (IN)				2.03	2.00	6.00	6.00	6.00	6.00	6.00	6.00	6.00	2.00	2.46			
TOP LIFT (IN)				2.00	2.00	2.50	2.50	2.50	2.50	2.50	2.50	2.50	2.00	2.00			
LIFT						2.50	2.50	2.50	2.50	2.50	2.50	2.50					
VARIABLE DEPTH LIFT (IN)				0.03	0.00	1.00	1.00	1.00	1.00	1.00	1.00	1.00	0.00	0.46			
194+50																	
MATCH EXISTING	152.70																123.33
EXISTING ELEV		885.12	885.06	885.06	885.54	885.54	885.79	886.01	886.24	886.05	885.82	885.56	885.56	884.97	884.97	885.02	
PROPOSED ELEV		884.52	885.02	885.15	885.58	885.58	885.84	886.09	886.34	886.08	885.82	885.57	885.57	885.14	885.01	884.51	
MILLED ELEV				884.98	885.42	885.08	885.34	885.59	885.84	885.58	885.32	885.07	885.40	884.93			
MILLED DEPTH (IN)				0.97	1.48	5.48	5.40	5.10	4.84	5.57	5.90	5.90	1.90	0.50			
PAVEMENT DEPTH (IN)				2.00	2.00	6.00	6.00	6.00	6.00	6.00	6.00	6.00	2.00	2.48			
TOP LIFT (IN)				2.00	2.00	2.50	2.50	2.50	2.50	2.50	2.50	2.50	2.00	2.00			
LIFT						2.50	2.50	2.50	2.50	2.50	2.50	2.50					
VARIABLE DEPTH LIFT (IN)				0.00	0.00	1.00	1.00	1.00	1.00	1.00	1.00	1.00	0.00	0.48			
194+75																	
MATCH EXISTING	153.13																121.81
EXISTING ELEV		885.23	885.00	885.00	885.52	885.52	885.78	886.01	886.23	886.03	885.81	885.53	885.53	884.94	884.94	884.89	
PROPOSED ELEV		884.52	885.02	885.15	885.58	885.58	885.83	886.09	886.34	886.08	885.82	885.57	885.57	885.15	885.02	884.52	
MILLED ELEV				884.96	885.42	885.08	885.33	885.59	885.84	885.58	885.32	885.07	885.40	884.89			
MILLED DEPTH (IN)				0.50	1.29	5.29	5.30	5.10	4.77	5.42	5.87	5.56	1.56	0.50			
PAVEMENT DEPTH (IN)				2.20	2.00	6.00	6.00	6.00	6.00	6.00	6.00	6.00	2.00	3.04			
TOP LIFT (IN)				2.00	2.00	2.50	2.50	2.50	2.50	2.50	2.50	2.50	2.00	2.00			
LIFT						2.50	2.50	2.50	2.50	2.50	2.50	2.50					
VARIABLE DEPTH LIFT (IN)				0.20	0.00	1.00	1.00	1.00	1.00	1.00	1.00	1.00	0.00	1.04			
195+00																	
MATCH EXISTING	152.54																129.71
EXISTING ELEV		885.13	885.02	885.02	885.53	885.53	885.79	886.03	886.24	886.04	885.83	885.54	885.54	884.93	884.93	884.92	
PROPOSED ELEV		884.52	885.02	885.14	885.58	885.58	885.83	886.08	886.33	886.08	885.82	885.56	885.56	885.16	885.03	884.53	
MILLED ELEV				884.98	885.41	885.08	885.33	885.58	885.83	885.58	885.32	885.06	885.40	884.89			
MILLED DEPTH (IN)				0.50	1.45	5.45	5.53	5.34	4.86	5.58	6.07	5.71	1.71	0.50			

PAVEMENT DEPTH (IN)				2.01	2.00	6.00	6.00	6.00	6.00	6.00	6.00	6.00	2.00	3.19			
TOP LIFT (IN)				2.00	2.00	2.50	2.50	2.50	2.50	2.50	2.50	2.50	2.00	2.00			
LIFT						2.50	2.50	2.50	2.50	2.50	2.50	2.50					
VARIABLE DEPTH LIFT (IN)				0.01	0.00	1.00	1.00	1.00	1.00	1.00	1.00	1.00	0.00	1.19			

	OFFSET LEFT	110' LEFT (TURF)	SHOULDER EDGE LEFT (TURF)	SHOULDER EDGE LEFT (PAVEMENT)	75' LEFT (SHOULDER)	75' LEFT (RUNWAY)	50' LEFT	25' LEFT	CENTERLINE	25' RIGHT	50' RIGHT	75' RIGHT (RUNWAY)	75' RIGHT (SHOULDER)	SHOULDER EDGE RIGHT (PAVEMENT)	SHOULDER EDGE RIGHT (TURF)	110' RIGHT (TURF)	OFFSET RIGHT
--	-------------	------------------	---------------------------	-------------------------------	---------------------	-------------------	----------	----------	------------	-----------	-----------	--------------------	----------------------	--------------------------------	----------------------------	-------------------	--------------

195+25

MATCH EXISTING	161.53																134.78
EXISTING ELEV		885.09	885.06	885.06	885.56	885.56	885.81	886.04	886.24	886.04	885.83	885.61	885.61	884.97	884.97	884.97	
PROPOSED ELEV		884.52	885.02	885.14	885.58	885.58	885.83	886.08	886.33	886.08	885.82	885.56	885.56	885.16	885.04	884.54	
MILLED ELEV				884.98	885.41	885.08	885.33	885.58	885.83	885.58	885.32	885.06	885.40	884.93			
MILLED DEPTH (IN)				1.02	1.73	5.73	5.73	5.47	4.93	5.57	6.18	6.59	2.59	0.50			
PAVEMENT DEPTH (IN)				2.00	2.00	6.00	6.00	6.00	6.00	6.00	6.00	6.00	2.00	2.84			
TOP LIFT (IN)				2.00	2.00	2.50	2.50	2.50	2.50	2.50	2.50	2.50	2.00	2.00			
LIFT						2.50	2.50	2.50	2.50	2.50	2.50	2.50					
VARIABLE DEPTH LIFT (IN)				0.00	0.00	1.00	1.00	1.00	1.00	1.00	1.00	1.00	0.00	0.84			

	OFFSET LEFT	110' LEFT (TURF)	SHOULDER EDGE LEFT (TURF)	SHOULDER EDGE LEFT (PAVEMENT)	75' LEFT (SHOULDER)	75' LEFT (RUNWAY)	50' LEFT	25' LEFT	CENTERLINE	25' RIGHT	50' RIGHT	75' RIGHT (RUNWAY)	75' RIGHT (SHOULDER)	SHOULDER EDGE RIGHT (PAVEMENT)	SHOULDER EDGE RIGHT (TURF)	110' RIGHT (TURF)	OFFSET RIGHT
--	-------------	------------------	---------------------------	-------------------------------	---------------------	-------------------	----------	----------	------------	-----------	-----------	--------------------	----------------------	--------------------------------	----------------------------	-------------------	--------------

195+50

MATCH EXISTING	163.78																132.36
EXISTING ELEV		885.09	885.06	885.06	885.56	885.56	885.80	886.03	886.25	886.04	885.84	885.61	885.61	885.01	885.01	885.04	
PROPOSED ELEV		884.52	885.02	885.14	885.58	885.58	885.83	886.08	886.33	886.07	885.82	885.56	885.56	885.16	885.04	884.54	
MILLED ELEV				884.97	885.41	885.08	885.33	885.58	885.83	885.57	885.32	885.06	885.39	884.97			
MILLED DEPTH (IN)				0.98	1.79	5.79	5.67	5.37	5.09	5.63	6.22	6.60	2.60	0.50			
PAVEMENT DEPTH (IN)				2.00	2.00	6.00	6.00	6.00	6.00	6.00	6.00	6.00	2.00	2.36			
TOP LIFT (IN)				2.00	2.00	2.50	2.50	2.50	2.50	2.50	2.50	2.50	2.00	2.00			
LIFT						2.50	2.50	2.50	2.50	2.50	2.50	2.50					
VARIABLE DEPTH LIFT (IN)				0.00	0.00	1.00	1.00	1.00	1.00	1.00	1.00	1.00	0.00	0.36			

	OFFSET LEFT	110' LEFT (TURF)	SHOULDER EDGE LEFT (TURF)	SHOULDER EDGE LEFT (PAVEMENT)	75' LEFT (SHOULDER)	75' LEFT (RUNWAY)	50' LEFT	25' LEFT	CENTERLINE	25' RIGHT	50' RIGHT	75' RIGHT (RUNWAY)	75' RIGHT (SHOULDER)	SHOULDER EDGE RIGHT (PAVEMENT)	SHOULDER EDGE RIGHT (TURF)	110' RIGHT (TURF)	OFFSET RIGHT
--	-------------	------------------	---------------------------	-------------------------------	---------------------	-------------------	----------	----------	------------	-----------	-----------	--------------------	----------------------	--------------------------------	----------------------------	-------------------	--------------

195+75

MATCH EXISTING	166.08																134.56
EXISTING ELEV		885.10	885.01	885.01	885.49	885.49	885.77	886.01	886.25	886.04	885.84	885.58	885.58	885.01	885.01	885.10	
PROPOSED ELEV		884.51	885.01	885.14	885.57	885.57	885.82	886.08	886.33	886.07	885.82	885.56	885.56	885.15	885.02	884.52	
MILLED ELEV				884.96	885.41	885.07	885.32	885.58	885.83	885.57	885.32	885.06	885.39	884.97			
MILLED DEPTH (IN)				0.50	1.01	5.01	5.37	5.25	5.04	5.65	6.25	6.29	2.29	0.50			
PAVEMENT DEPTH (IN)				2.10	2.00	6.00	6.00	6.00	6.00	6.00	6.00	6.00	2.00	2.21			
TOP LIFT (IN)				2.00	2.00	2.50	2.50	2.50	2.50	2.50	2.50	2.50	2.00	2.00			
LIFT						2.50	2.50	2.50	2.50	2.50	2.50	2.50					
VARIABLE DEPTH LIFT (IN)				0.10	0.00	1.00	1.00	1.00	1.00	1.00	1.00	1.00	0.00	0.21			

	OFFSET LEFT	110' LEFT (TURF)	SHOULDER EDGE LEFT (TURF)	SHOULDER EDGE LEFT (PAVEMENT)	75' LEFT (SHOULDER)	75' LEFT (RUNWAY)	50' LEFT	25' LEFT	CENTERLINE	25' RIGHT	50' RIGHT	75' RIGHT (RUNWAY)	75' RIGHT (SHOULDER)	SHOULDER EDGE RIGHT (PAVEMENT)	SHOULDER EDGE RIGHT (TURF)	110' RIGHT (TURF)	OFFSET RIGHT
--	-------------	------------------	---------------------------	-------------------------------	---------------------	-------------------	----------	----------	------------	-----------	-----------	--------------------	----------------------	--------------------------------	----------------------------	-------------------	--------------

196+00

MATCH EXISTING	170.09																135.89
EXISTING ELEV		885.09	884.98	884.98	885.49	885.49	885.77	886.01	886.27	886.04	885.83	885.57	885.57	884.99	884.99	885.22	
PROPOSED ELEV		884.51	885.01	885.14	885.57	885.57	885.82	886.07	886.32	886.07	885.81	885.56	885.56	885.14	885.01	884.51	
MILLED ELEV				884.94	885.40	885.07	885.32	885.57	885.82	885.57	885.31	885.06	885.39	884.95			
MILLED DEPTH (IN)				0.50	0.99	4.99	5.42	5.28	5.37	5.68	6.18	6.14	2.14	0.50			
PAVEMENT DEPTH (IN)				2.42	2.00	6.00	6.00	6.00	6.00	6.00	6.00	6.00	2.00	2.23			
TOP LIFT (IN)				2.00	2.00	2.50	2.50	2.50	2.50	2.50	2.50	2.50	2.00	2.00			
LIFT						2.50	2.50	2.50	2.50	2.50	2.50	2.50					
VARIABLE DEPTH LIFT (IN)				0.42	0.00	1.00	1.00	1.00	1.00	1.00	1.00	1.00	0.00	0.23			

	OFFSET LEFT	110' LEFT (TURF)	SHOULDER EDGE LEFT (TURF)	SHOULDER EDGE LEFT (PAVEMENT)	75' LEFT (SHOULDER)	75' LEFT (RUNWAY)	50' LEFT	25' LEFT	CENTERLINE	25' RIGHT	50' RIGHT	75' RIGHT (RUNWAY)	75' RIGHT (SHOULDER)	SHOULDER EDGE RIGHT (PAVEMENT)	SHOULDER EDGE RIGHT (TURF)	110' RIGHT (TURF)	OFFSET RIGHT
196+25																	
MATCH EXISTING	173.95																135.84
EXISTING ELEV		885.04	885.01	885.01	885.51	885.51	885.78	886.03	886.26	886.05	885.82	885.56	885.56	884.98	884.98	885.03	
PROPOSED ELEV		884.51	885.01	885.14	885.57	885.57	885.82	886.07	886.32	886.07	885.81	885.56	885.56	885.13	885.00	884.50	
MILLED ELEV				884.97	885.40	885.07	885.32	885.57	885.82	885.57	885.31	885.06	885.39	884.94			
MILLED DEPTH (IN)				0.52	1.35	5.35	5.58	5.50	5.26	5.82	6.08	6.07	2.07	0.50			
PAVEMENT DEPTH (IN)				2.00	2.00	6.00	6.00	6.00	6.00	6.00	6.00	6.00	2.00	2.25			
TOP LIFT (IN)				2.00	2.00	2.50	2.50	2.50	2.50	2.50	2.50	2.50	2.00	2.00			
LIFT						2.50	2.50	2.50	2.50	2.50	2.50	2.50					
VARIABLE DEPTH LIFT (IN)				0.00	0.00	1.00	1.00	1.00	1.00	1.00	1.00	1.00	0.00	0.25			

	OFFSET LEFT	110' LEFT (TURF)	SHOULDER EDGE LEFT (TURF)	SHOULDER EDGE LEFT (PAVEMENT)	75' LEFT (SHOULDER)	75' LEFT (RUNWAY)	50' LEFT	25' LEFT	CENTERLINE	25' RIGHT	50' RIGHT	75' RIGHT (RUNWAY)	75' RIGHT (SHOULDER)	SHOULDER EDGE RIGHT (PAVEMENT)	SHOULDER EDGE RIGHT (TURF)	110' RIGHT (TURF)	OFFSET RIGHT
196+50																	
MATCH EXISTING	179.89																134.92
EXISTING ELEV		885.02	885.07	885.07	885.53	885.53	885.78	886.03	886.27	886.04	885.82	885.57	885.57	884.96	884.96	884.90	
PROPOSED ELEV		884.51	885.01	885.13	885.57	885.57	885.82	886.07	886.32	886.06	885.81	885.56	885.56	885.10	884.98	884.48	
MILLED ELEV				884.97	885.40	885.07	885.32	885.57	885.82	885.56	885.31	885.06	885.39	884.92			
MILLED DEPTH (IN)				1.19	1.57	5.57	5.55	5.55	5.36	5.76	6.11	6.20	2.20	0.50			
PAVEMENT DEPTH (IN)				2.00	2.00	6.00	6.00	6.00	6.00	6.00	6.00	6.00	2.00	2.20			
TOP LIFT (IN)				2.00	2.00	2.50	2.50	2.50	2.50	2.50	2.50	2.50	2.00	2.00			
LIFT						2.50	2.50	2.50	2.50	2.50	2.50	2.50					
VARIABLE DEPTH LIFT (IN)				0.00	0.00	1.00	1.00	1.00	1.00	1.00	1.00	1.00	0.00	0.20			

	OFFSET LEFT	110' LEFT (TURF)	SHOULDER EDGE LEFT (TURF)	SHOULDER EDGE LEFT (PAVEMENT)	75' LEFT (SHOULDER)	75' LEFT (RUNWAY)	50' LEFT	25' LEFT	CENTERLINE	25' RIGHT	50' RIGHT	75' RIGHT (RUNWAY)	75' RIGHT (SHOULDER)	SHOULDER EDGE RIGHT (PAVEMENT)	SHOULDER EDGE RIGHT (TURF)	110' RIGHT (TURF)	OFFSET RIGHT
196+75																	
MATCH EXISTING	180.43																129.30
EXISTING ELEV		885.00	885.03	885.03	885.51	885.51	885.78	886.02	886.25	886.03	885.80	885.53	885.53	884.94	884.94	884.86	
PROPOSED ELEV		884.51	885.01	885.13	885.56	885.56	885.82	886.07	886.32	886.06	885.81	885.55	885.55	885.08	884.96	884.46	
MILLED ELEV				884.97	885.40	885.06	885.32	885.57	885.82	885.56	885.31	885.05	885.39	884.90			
MILLED DEPTH (IN)				0.82	1.34	5.34	5.52	5.42	5.17	5.60	5.88	5.69	1.69	0.50			
PAVEMENT DEPTH (IN)				2.00	2.00	6.00	6.00	6.00	6.00	6.00	6.00	6.00	2.00	2.21			
TOP LIFT (IN)				2.00	2.00	2.50	2.50	2.50	2.50	2.50	2.50	2.50	2.00	2.00			
LIFT						2.50	2.50	2.50	2.50	2.50	2.50	2.50					
VARIABLE DEPTH LIFT (IN)				0.00	0.00	1.00	1.00	1.00	1.00	1.00	1.00	1.00	0.00	0.21			

	OFFSET LEFT	110' LEFT (TURF)	SHOULDER EDGE LEFT (TURF)	SHOULDER EDGE LEFT (PAVEMENT)	75' LEFT (SHOULDER)	75' LEFT (RUNWAY)	50' LEFT	25' LEFT	CENTERLINE	25' RIGHT	50' RIGHT	75' RIGHT (RUNWAY)	75' RIGHT (SHOULDER)	SHOULDER EDGE RIGHT (PAVEMENT)	SHOULDER EDGE RIGHT (TURF)	110' RIGHT (TURF)	OFFSET RIGHT
197+00																	
MATCH EXISTING	184.02																121.22
EXISTING ELEV		884.95	885.07	885.07	885.51	885.51	885.76	886.00	886.24	886.02	885.79	885.54	885.54	884.93	884.93	884.84	
PROPOSED ELEV		884.51	885.01	885.13	885.56	885.56	885.81	886.06	886.31	886.06	885.81	885.55	885.55	885.06	884.94	884.44	
MILLED ELEV				884.96	885.40	885.06	885.31	885.56	885.81	885.56	885.31	885.05	885.39	884.89			
MILLED DEPTH (IN)				1.24	1.43	5.43	5.33	5.29	5.05	5.48	5.80	5.83	1.83	0.50			
PAVEMENT DEPTH (IN)				2.00	2.00	6.00	6.00	6.00	6.00	6.00	6.00	6.00	2.00	2.04			
TOP LIFT (IN)				2.00	2.00	2.50	2.50	2.50	2.50	2.50	2.50	2.50	2.00	2.00			
LIFT						2.50	2.50	2.50	2.50	2.50	2.50	2.50					
VARIABLE DEPTH LIFT (IN)				0.00	0.00	1.00	1.00	1.00	1.00	1.00	1.00	1.00	0.00	0.04			
197+25																	
MATCH EXISTING	168.87																117.53
EXISTING ELEV		884.92	885.05	885.05	885.46	885.46	885.74	886.00	886.21	885.99	885.76	885.50	885.50	884.95	884.95	884.76	
PROPOSED ELEV		884.51	885.01	885.13	885.56	885.56	885.81	886.06	886.31	886.06	885.80	885.55	885.55	885.07	884.94	884.44	
MILLED ELEV				884.96	885.39	885.06	885.31	885.56	885.81	885.56	885.30	885.05	885.38	884.90			
MILLED DEPTH (IN)				1.00	0.85	4.85	5.11	5.22	4.78	5.20	5.52	5.39	1.39	0.63			
PAVEMENT DEPTH (IN)				2.00	2.00	6.00	6.00	6.00	6.00	6.00	6.00	6.00	2.00	2.00			
TOP LIFT (IN)				2.00	2.00	2.50	2.50	2.50	2.50	2.50	2.50	2.50	2.00	2.00			
LIFT						2.50	2.50	2.50	2.50	2.50	2.50	2.50					
VARIABLE DEPTH LIFT (IN)				0.00	0.00	1.00	1.00	1.00	1.00	1.00	1.00	1.00	0.00	0.00			
197+50																	
MATCH EXISTING	172.47																114.29
EXISTING ELEV		884.87	885.03	885.03	885.47	885.47	885.73	885.98	886.21	885.98	885.75	885.49	885.49	884.94	884.94	884.63	
PROPOSED ELEV		884.52	885.02	885.14	885.56	885.56	885.81	886.06	886.31	886.06	885.80	885.55	885.55	885.08	884.96	884.46	
MILLED ELEV				884.98	885.39	885.06	885.31	885.56	885.81	885.56	885.30	885.05	885.38	884.90			
MILLED DEPTH (IN)				0.61	0.97	4.97	5.11	5.06	4.85	5.04	5.43	5.33	1.33	0.50			
PAVEMENT DEPTH (IN)				2.00	2.00	6.00	6.00	6.00	6.00	6.00	6.00	6.00	2.00	2.24			
TOP LIFT (IN)				2.00	2.00	2.50	2.50	2.50	2.50	2.50	2.50	2.50	2.00	2.00			
LIFT						2.50	2.50	2.50	2.50	2.50	2.50	2.50					
VARIABLE DEPTH LIFT (IN)				0.00	0.00	1.00	1.00	1.00	1.00	1.00	1.00	1.00	0.00	0.24			
197+75																	
MATCH EXISTING	157.70																117.28
EXISTING ELEV		885.02	885.01	885.01	885.47	885.47	885.72	885.96	886.19	885.97	885.74	885.46	885.46	884.96			
PROPOSED ELEV		884.53	885.03	885.15	885.55	885.55	885.81	886.06	886.31	886.05	885.80	885.55	885.55	885.10			
MILLED ELEV				884.97	885.39	885.05	885.31	885.56	885.81	885.55	885.30	885.05	885.38	884.92			
MILLED DEPTH (IN)				0.50	1.02	5.02	4.96	4.90	4.61	4.94	5.26	4.91	0.91	0.50			

PAVEMENT DEPTH (IN)				2.21	2.00	6.00	6.00	6.00	6.00	6.00	6.00	6.00	2.00	2.21			
TOP LIFT (IN)				2.00	2.00	2.50	2.50	2.50	2.50	2.50	2.50	2.50	2.00	2.00			
LIFT						2.50	2.50	2.50	2.50	2.50	2.50	2.50					
VARIABLE DEPTH LIFT (IN)				0.21	0.00	1.00	1.00	1.00	1.00	1.00	1.00	1.00	0.00	0.21			
	OFFSET LEFT	110' LEFT (TURF)	SHOULDER EDGE LEFT (TURF)	SHOULDER EDGE LEFT (PAVEMENT)	75' LEFT (SHOULDER)	75' LEFT (RUNWAY)	50' LEFT	25' LEFT	CENTERLINE	25' RIGHT	50' RIGHT	75' RIGHT (RUNWAY)	75' RIGHT (SHOULDER)	SHOULDER EDGE RIGHT (PAVEMENT)	SHOULDER EDGE RIGHT (TURF)	110' RIGHT (TURF)	OFFSET RIGHT
198+00																	
MATCH EXISTING	142.43																118.90
EXISTING ELEV		885.15	885.13	885.13	885.49	885.49	885.71	885.96	886.18	885.96	885.72	885.46	885.46	884.96			
PROPOSED ELEV		884.54	885.04	885.17	885.55	885.55	885.80	886.05	886.30	886.05	885.80	885.55	885.55	885.10			
MILLED ELEV				885.00	885.39	885.05	885.30	885.55	885.80	885.55	885.30	885.05	885.38	884.92			
MILLED DEPTH (IN)				1.52	1.27	5.27	4.89	4.83	4.50	4.86	5.07	4.96	0.96	0.50			
PAVEMENT DEPTH (IN)				2.00	2.00	6.00	6.00	6.00	6.00	6.00	6.00	6.00	2.00	2.17			
TOP LIFT (IN)				2.00	2.00	2.50	2.50	2.50	2.50	2.50	2.50	2.50	2.00	2.00			
LIFT						2.50	2.50	2.50	2.50	2.50	2.50	2.50					
VARIABLE DEPTH LIFT (IN)				0.00	0.00	1.00	1.00	1.00	1.00	1.00	1.00	1.00	0.00	0.17			
	OFFSET LEFT	110' LEFT (TURF)	SHOULDER EDGE LEFT (TURF)	SHOULDER EDGE LEFT (PAVEMENT)	75' LEFT (SHOULDER)	75' LEFT (RUNWAY)	50' LEFT	25' LEFT	CENTERLINE	25' RIGHT	50' RIGHT	75' RIGHT (RUNWAY)	75' RIGHT (SHOULDER)	SHOULDER EDGE RIGHT (PAVEMENT)	SHOULDER EDGE RIGHT (TURF)	110' RIGHT (TURF)	OFFSET RIGHT
198+25																	
MATCH EXISTING	127.16																121.08
EXISTING ELEV		885.00	885.09	885.09	885.47	885.47	885.71	885.94	886.18	885.95	885.70	885.44	885.44	885.00			
PROPOSED ELEV		884.53	885.01	885.14	885.55	885.55	885.80	886.05	886.30	886.05	885.80	885.54	885.54	885.09			
MILLED ELEV				884.97	885.38	885.05	885.30	885.55	885.80	885.55	885.30	885.04	885.38	884.93			
MILLED DEPTH (IN)				1.37	0.98	4.98	4.88	4.67	4.52	4.79	4.86	4.71	0.71	0.94			
PAVEMENT DEPTH (IN)				2.00	2.00	6.00	6.00	6.00	6.00	6.00	6.00	6.00	2.00	2.00			
TOP LIFT (IN)				2.00	2.00	2.50	2.50	2.50	2.50	2.50	2.50	2.50	2.00	2.00			
LIFT						2.50	2.50	2.50	2.50	2.50	2.50	2.50					
VARIABLE DEPTH LIFT (IN)				0.00	0.00	1.00	1.00	1.00	1.00	1.00	1.00	1.00	0.00	0.00			
	OFFSET LEFT	110' LEFT (TURF)	SHOULDER EDGE LEFT (TURF)	SHOULDER EDGE LEFT (PAVEMENT)	75' LEFT (SHOULDER)	75' LEFT (RUNWAY)	50' LEFT	25' LEFT	CENTERLINE	25' RIGHT	50' RIGHT	75' RIGHT (RUNWAY)	75' RIGHT (SHOULDER)	SHOULDER EDGE RIGHT (PAVEMENT)	SHOULDER EDGE RIGHT (TURF)	110' RIGHT (TURF)	OFFSET RIGHT
198+50																	
MATCH EXISTING	114.98																123.25
EXISTING ELEV				885.03	885.46	885.46	885.71	885.93	886.18	885.95	885.72	885.46	885.46	885.01			
PROPOSED ELEV				885.10	885.55	885.55	885.80	886.05	886.30	886.05	885.80	885.54	885.54	885.09			
MILLED ELEV				884.93	885.38	885.05	885.30	885.55	885.80	885.55	885.30	885.04	885.38	884.92			
MILLED DEPTH (IN)				1.23	0.97	4.97	4.98	4.60	4.52	4.83	5.07	4.97	0.97	1.00			
PAVEMENT DEPTH (IN)				2.00	2.00	6.00	6.00	6.00	6.00	6.00	6.00	6.00	2.00	2.00			
TOP LIFT (IN)				2.00	2.00	2.50	2.50	2.50	2.50	2.50	2.50	2.50	2.00	2.00			
LIFT						2.50	2.50	2.50	2.50	2.50	2.50	2.50					
VARIABLE DEPTH LIFT (IN)				0.00	0.00	1.00	1.00	1.00	1.00	1.00	1.00	1.00	0.00	0.00			
	OFFSET LEFT	110' LEFT (TURF)	SHOULDER EDGE LEFT (TURF)	SHOULDER EDGE LEFT (PAVEMENT)	75' LEFT (SHOULDER)	75' LEFT (RUNWAY)	50' LEFT	25' LEFT	CENTERLINE	25' RIGHT	50' RIGHT	75' RIGHT (RUNWAY)	75' RIGHT (SHOULDER)	SHOULDER EDGE RIGHT (PAVEMENT)	SHOULDER EDGE RIGHT (TURF)	110' RIGHT (TURF)	OFFSET RIGHT
198+75																	

MATCH EXISTING	114.98																	125.02
EXISTING ELEV				884.95	885.43	885.43	885.71	885.93	886.15	885.94	885.73	885.47	885.47	884.99				
PROPOSED ELEV				885.14	885.55	885.55	885.80	886.05	886.30	886.05	885.79	885.54	885.54	885.05				
MILLED ELEV				884.91	885.38	885.05	885.30	885.55	885.80	885.55	885.29	885.04	885.38	884.88				
MILLED DEPTH (IN)				0.50	0.64	4.64	4.91	4.58	4.18	4.79	5.20	5.13	1.13	1.34				
PAVEMENT DEPTH (IN)				2.77	2.00	6.00	6.00	6.00	6.00	6.00	6.00	6.00	2.00	2.00				
TOP LIFT (IN)				2.00	2.00	2.50	2.50	2.50	2.50	2.50	2.50	2.50	2.00	2.00				
LIFT						2.50	2.50	2.50	2.50	2.50	2.50	2.50						
VARIABLE DEPTH LIFT (IN)				0.77	0.00	1.00	1.00	1.00	1.00	1.00	1.00	1.00	0.00	0.00				

	OFFSET LEFT	110' LEFT (TURF)	SHOULDER EDGE LEFT (TURF)	SHOULDER EDGE LEFT (PAVEMENT)	75' LEFT (SHOULDER)	75' LEFT (RUNWAY)	50' LEFT	25' LEFT	CENTERLINE	25' RIGHT	50' RIGHT	75' RIGHT (RUNWAY)	75' RIGHT (SHOULDER)	SHOULDER EDGE RIGHT (PAVEMENT)	SHOULDER EDGE RIGHT (TURF)	110' RIGHT (TURF)	OFFSET RIGHT
--	-------------	------------------	---------------------------	-------------------------------	---------------------	-------------------	----------	----------	------------	-----------	-----------	--------------------	----------------------	--------------------------------	----------------------------	-------------------	--------------

199+00																		
MATCH EXISTING	114.98																	125.02
EXISTING ELEV				885.07	885.45	885.45	885.70	885.92	886.15	885.94	885.72	885.48	885.48	885.03				
PROPOSED ELEV				885.17	885.54	885.54	885.79	886.04	886.29	886.04	885.79	885.54	885.54	885.06				
MILLED ELEV				885.01	885.38	885.04	885.29	885.54	885.79	885.54	885.29	885.04	885.37	884.89				
MILLED DEPTH (IN)				0.69	0.93	4.93	4.84	4.55	4.31	4.82	5.18	5.28	1.28	1.59				
PAVEMENT DEPTH (IN)				2.00	2.00	6.00	6.00	6.00	6.00	6.00	6.00	6.00	2.00	2.00				
TOP LIFT (IN)				2.00	2.00	2.50	2.50	2.50	2.50	2.50	2.50	2.50	2.00	2.00				
LIFT						2.50	2.50	2.50	2.50	2.50	2.50	2.50						
VARIABLE DEPTH LIFT (IN)				0.00	0.00	1.00	1.00	1.00	1.00	1.00	1.00	1.00	0.00	0.00				

	OFFSET LEFT	110' LEFT (TURF)	SHOULDER EDGE LEFT (TURF)	SHOULDER EDGE LEFT (PAVEMENT)	75' LEFT (SHOULDER)	75' LEFT (RUNWAY)	50' LEFT	25' LEFT	CENTERLINE	25' RIGHT	50' RIGHT	75' RIGHT (RUNWAY)	75' RIGHT (SHOULDER)	SHOULDER EDGE RIGHT (PAVEMENT)	SHOULDER EDGE RIGHT (TURF)	110' RIGHT (TURF)	OFFSET RIGHT
--	-------------	------------------	---------------------------	-------------------------------	---------------------	-------------------	----------	----------	------------	-----------	-----------	--------------------	----------------------	--------------------------------	----------------------------	-------------------	--------------

199+25																		
MATCH EXISTING	114.98																	125.02
EXISTING ELEV				885.09	885.40	885.40	885.65	885.90	886.14	885.98	885.74	885.47	885.47	885.06				
PROPOSED ELEV				885.20	885.54	885.54	885.79	886.04	886.29	886.04	885.79	885.54	885.54	885.08				
MILLED ELEV				885.03	885.35	885.04	885.29	885.54	885.79	885.54	885.29	885.04	885.37	884.91				
MILLED DEPTH (IN)				0.75	0.50	4.25	4.35	4.29	4.13	5.22	5.36	5.18	1.18	1.75				
PAVEMENT DEPTH (IN)				2.00	2.25	6.00	6.00	6.00	6.00	6.00	6.00	6.00	2.00	2.00				
TOP LIFT (IN)				2.00	2.00	2.50	2.50	2.50	2.50	2.50	2.50	2.50	2.00	2.00				
LIFT						2.50	2.50	2.50	2.50	2.50	2.50	2.50						
VARIABLE DEPTH LIFT (IN)				0.00	0.25	1.00	1.00	1.00	1.00	1.00	1.00	1.00	0.00	0.00				

	OFFSET LEFT	110' LEFT (TURF)	SHOULDER EDGE LEFT (TURF)	SHOULDER EDGE LEFT (PAVEMENT)	75' LEFT (SHOULDER)	75' LEFT (RUNWAY)	50' LEFT	25' LEFT	CENTERLINE	25' RIGHT	50' RIGHT	75' RIGHT (RUNWAY)	75' RIGHT (SHOULDER)	SHOULDER EDGE RIGHT (PAVEMENT)	SHOULDER EDGE RIGHT (TURF)	110' RIGHT (TURF)	OFFSET RIGHT
--	-------------	------------------	---------------------------	-------------------------------	---------------------	-------------------	----------	----------	------------	-----------	-----------	--------------------	----------------------	--------------------------------	----------------------------	-------------------	--------------

199+50																		
MATCH EXISTING	114.98																	125.02
EXISTING ELEV				885.09	885.32	885.32	885.58	885.83	886.08	885.92	885.69	885.44	885.44	885.02				
PROPOSED ELEV				885.19	885.54	885.54	885.79	886.04	886.29	886.04	885.79	885.54	885.54	885.11				
MILLED ELEV				885.03	885.28	885.04	885.29	885.54	885.79	885.54	885.29	885.04	885.37	884.94				
MILLED DEPTH (IN)				0.78	0.50	3.33	3.55	3.51	3.51	4.53	4.78	4.81	0.81	0.94				
PAVEMENT DEPTH (IN)				2.00	3.17	6.00	6.00	6.00	6.00	6.00	6.00	6.00	2.00	2.00				
TOP LIFT (IN)				2.00	2.00	2.50	2.50	2.50	2.50	2.50	2.50	2.50	2.00	2.00				
LIFT						2.50	2.50	2.50	2.50	2.50	2.50	2.50						
VARIABLE DEPTH LIFT (IN)				0.00	1.17	1.00	1.00	1.00	1.00	1.00	1.00	1.00	0.00	0.00				

	OFFSET LEFT	110' LEFT (TURF)	SHOULDER EDGE LEFT (TURF)	SHOULDER EDGE LEFT (PAVEMENT)	75' LEFT (SHOULDER)	75' LEFT (RUNWAY)	50' LEFT	25' LEFT	CENTERLINE	25' RIGHT	50' RIGHT	75' RIGHT (RUNWAY)	75' RIGHT (SHOULDER)	SHOULDER EDGE RIGHT (PAVEMENT)	SHOULDER EDGE RIGHT (TURF)	110' RIGHT (TURF)	OFFSET RIGHT
199+75																	
MATCH EXISTING	114.98																125.02
EXISTING ELEV				885.07	885.28	885.28	885.51	885.72	885.94	885.86	885.56	885.27	885.27	884.94			
PROPOSED ELEV				885.17	885.54	885.54	885.79	886.04	886.29	886.04	885.79	885.54	885.54	885.09			
MILLED ELEV				885.00	885.24	885.03	885.26	885.47	885.69	885.54	885.29	885.02	885.23	884.89			
MILLED DEPTH (IN)				0.90	0.50	3.00	3.00	3.00	3.00	3.92	3.27	3.00	0.50	0.50			
PAVEMENT DEPTH (IN)				2.00	3.58	6.08	6.38	6.77	7.20	6.00	6.00	6.19	3.69	2.37			
TOP LIFT (IN)				2.00	2.00	2.50	2.50	2.50	2.50	2.50	2.50	2.50	2.00	2.00			
LIFT						2.50	2.50	2.50	2.50	2.50	2.50	2.50					
VARIABLE DEPTH LIFT (IN)				0.00	1.58	1.08	1.38	1.77	2.20	1.00	1.00	1.19	1.69	0.37			
200+00																	
MATCH EXISTING	115.06																125.01
EXISTING ELEV				885.00	885.18	885.18	885.38	885.60	885.77	885.64	885.39	885.12	885.12	884.79			
PROPOSED ELEV				885.10	885.53	885.53	885.78	886.03	886.28	886.03	885.78	885.53	885.53	885.03			
MILLED ELEV				884.93	885.14	884.93	885.13	885.35	885.52	885.39	885.14	884.87	885.08	884.75			
MILLED DEPTH (IN)				0.87	0.50	3.00	3.00	3.00	3.00	3.00	3.00	3.00	0.50	0.50			
PAVEMENT DEPTH (IN)				2.00	4.79	7.29	7.83	8.18	9.21	7.71	7.69	7.99	5.49	3.41			
TOP LIFT (IN)				2.00	2.00	2.50	2.50	2.50	2.50	2.50	2.50	2.50	2.00	2.00			
LIFT						2.50	2.50	2.50	2.50	2.50	2.50	2.50					
VARIABLE DEPTH LIFT (IN)				0.00	2.79	2.29	2.83	3.18	4.21	2.71	2.69	2.99	3.49	1.41			
200+25																	
MATCH EXISTING	115.99																125.01
EXISTING ELEV				884.91	885.21	885.21	885.40	885.63	885.89	885.65	885.40	885.14	885.14	884.91	884.91		
PROPOSED ELEV				885.07	885.50	885.50	885.75	886.00	886.25	886.00	885.74	885.49	885.49	885.03	884.90		
MILLED ELEV				884.87	885.17	885.17	885.35	885.59	885.85	885.61	885.36	885.10	885.10	884.86			
MILLED DEPTH (IN)				0.50	0.50	0.50	0.50	0.50	0.50	0.50	0.50	0.50	0.50	0.59			
PAVEMENT DEPTH (IN)				2.45	4.03	4.03	4.80	4.95	4.91	4.69	4.65	4.65	4.65	2.00			
TOP LIFT (IN)				2.00	2.00	2.00	2.00	2.00	2.00	2.00	2.00	2.00	2.00	2.00			
LIFT																	
VARIABLE DEPTH LIFT (IN)				0.45	2.03	2.03	2.80	2.95	2.91	2.69	2.65	2.65	2.65	0.00			
200+50																	
MATCH EXISTING	116.92																124.25
EXISTING ELEV				884.86	884.86	885.21	885.21	885.44	885.68	885.96	885.70	885.44	885.19	885.19	884.90	884.90	
PROPOSED ELEV				884.94	885.07	885.47	885.47	885.72	885.97	886.22	885.96	885.70	885.44	885.44	885.04	884.92	
MILLED ELEV				884.82	885.16	885.16	885.40	885.63	885.92	885.66	885.40	885.15	885.15	884.86			
MILLED DEPTH (IN)				0.50	0.50	0.50	0.50	0.50	0.50	0.50	0.50	0.50	0.50	0.50			

PAVEMENT DEPTH (IN)				2.93	3.70	3.70	3.87	4.09	3.68	3.63	3.63	3.50	3.50	2.17			
TOP LIFT (IN)				2.00	2.00	2.00	2.00	2.00	2.00	2.00	2.00	2.00	2.00	2.00			
LIFT																	
VARIABLE DEPTH LIFT (IN)				0.93	1.70	1.70	1.87	2.09	1.68	1.63	1.63	1.50	1.50	0.17			
	OFFSET LEFT	110' LEFT (TURF)	SHOULDER EDGE LEFT (TURF)	SHOULDER EDGE LEFT (PAVEMENT)	75' LEFT (SHOULDER)	75' LEFT (RUNWAY)	50' LEFT	25' LEFT	CENTERLINE	25' RIGHT	50' RIGHT	75' RIGHT (RUNWAY)	75' RIGHT (SHOULDER)	SHOULDER EDGE RIGHT (PAVEMENT)	SHOULDER EDGE RIGHT (TURF)	110' RIGHT (TURF)	OFFSET RIGHT
200+75																	
MATCH EXISTING	117.85																126.68
EXISTING ELEV		884.62	884.79	884.79	885.22	885.22	885.47	885.69	885.94	885.69	885.45	885.20	885.20	884.91	884.91	884.88	
PROPOSED ELEV		884.44	884.94	885.06	885.44	885.44	885.69	885.94	886.19	885.93	885.66	885.39	885.39	885.04	884.92	884.41	
MILLED ELEV				884.75	885.18	885.18	885.42	885.65	885.89	885.65	885.41	885.16	885.16	884.87			
MILLED DEPTH (IN)				0.50	0.50	0.50	0.50	0.50	0.50	0.50	0.50	0.50	0.50	0.50			
PAVEMENT DEPTH (IN)				3.74	3.19	3.19	3.21	3.58	3.61	3.29	2.99	2.80	2.80	2.07			
TOP LIFT (IN)				2.00	2.00	2.00	2.00	2.00	2.00	2.00	2.00	2.00	2.00	2.00			
LIFT																	
VARIABLE DEPTH LIFT (IN)				1.74	1.19	1.19	1.21	1.58	1.61	1.29	0.99	0.80	0.80	0.07			
	OFFSET LEFT	110' LEFT (TURF)	SHOULDER EDGE LEFT (TURF)	SHOULDER EDGE LEFT (PAVEMENT)	75' LEFT (SHOULDER)	75' LEFT (RUNWAY)	50' LEFT	25' LEFT	CENTERLINE	25' RIGHT	50' RIGHT	75' RIGHT (RUNWAY)	75' RIGHT (SHOULDER)	SHOULDER EDGE RIGHT (PAVEMENT)	SHOULDER EDGE RIGHT (TURF)	110' RIGHT (TURF)	OFFSET RIGHT
201+00																	
MATCH EXISTING	118.78																127.87
EXISTING ELEV		884.75	884.84	884.84	885.23	885.23	885.48	885.71	885.93	885.70	885.45	885.19	885.19	884.91	884.91	884.89	
PROPOSED ELEV		884.43	884.93	885.06	885.41	885.41	885.66	885.91	886.16	885.89	885.62	885.34	885.34	885.03	884.91	884.41	
MILLED ELEV				884.79	885.19	885.19	885.44	885.67	885.89	885.65	885.41	885.15	885.15	884.86			
MILLED DEPTH (IN)				0.50	0.50	0.50	0.50	0.50	0.50	0.50	0.50	0.50	0.50	0.50			
PAVEMENT DEPTH (IN)				3.13	2.66	2.66	2.64	2.90	3.30	2.85	2.53	2.37	2.37	2.01			
TOP LIFT (IN)				2.00	2.00	2.00	2.00	2.00	2.00	2.00	2.00	2.00	2.00	2.00			
LIFT																	
VARIABLE DEPTH LIFT (IN)				1.13	0.66	0.66	0.64	0.90	1.30	0.85	0.53	0.37	0.37	0.01			
	OFFSET LEFT	110' LEFT (TURF)	SHOULDER EDGE LEFT (TURF)	SHOULDER EDGE LEFT (PAVEMENT)	75' LEFT (SHOULDER)	75' LEFT (RUNWAY)	50' LEFT	25' LEFT	CENTERLINE	25' RIGHT	50' RIGHT	75' RIGHT (RUNWAY)	75' RIGHT (SHOULDER)	SHOULDER EDGE RIGHT (PAVEMENT)	SHOULDER EDGE RIGHT (TURF)	110' RIGHT (TURF)	OFFSET RIGHT
201+25																	
MATCH EXISTING	119.72																129.69
EXISTING ELEV		884.65	884.85	884.85	885.25	885.25	885.49	885.71	885.89	885.69	885.45	885.18	885.18	884.88	884.88	884.85	
PROPOSED ELEV		884.42	884.92	885.05	885.38	885.38	885.63	885.88	886.13	885.86	885.58	885.30	885.30	885.02	884.90	884.40	
MILLED ELEV				884.80	885.21	885.21	885.45	885.67	885.85	885.65	885.41	885.13	885.13	884.83			
MILLED DEPTH (IN)				0.50	0.50	0.50	0.50	0.50	0.50	0.50	0.50	0.60	0.60	0.50			
PAVEMENT DEPTH (IN)				2.93	2.05	2.05	2.15	2.59	3.47	2.46	2.02	2.00	2.00	2.24			
TOP LIFT (IN)				2.00	2.00	2.00	2.00	2.00	2.00	2.00	2.00	2.00	2.00	2.00			
LIFT																	
VARIABLE DEPTH LIFT (IN)				0.93	0.05	0.05	0.15	0.59	1.47	0.46	0.02	0.00	0.00	0.24			
	OFFSET LEFT	110' LEFT (TURF)	SHOULDER EDGE LEFT (TURF)	SHOULDER EDGE LEFT (PAVEMENT)	75' LEFT (SHOULDER)	75' LEFT (RUNWAY)	50' LEFT	25' LEFT	CENTERLINE	25' RIGHT	50' RIGHT	75' RIGHT (RUNWAY)	75' RIGHT (SHOULDER)	SHOULDER EDGE RIGHT (PAVEMENT)	SHOULDER EDGE RIGHT (TURF)	110' RIGHT (TURF)	OFFSET RIGHT
201+50																	

